

Mark 60 Series

Self-Operated Pressure Regulators

The MK60 Sliding Gate Pressure Regulator is used to regulate the downstream pressure to a predetermined setpoint. The spring in the Mark 60 holds the sliding gate seats in their normally open position to allow the process media to pass through the seats.

The downstream pressure is sensed beneath the diaphragm. As the downstream pressure exceeds the setpoint, pressure is exerted on the diaphragm which raises the stem to modulate the disc (the moveable component on the sliding gate seat set) toward the closed position. As the seats close, downstream pressure will be reduced to the required setpoint. A decrease in pressure relaxes the spring and diaphragm to move the seats toward the open position.

This brochure includes the following Series:

- **MK60:** a line of self-operating pressure regulators designed with Jordan Valve's sliding gate seats
- **MK61:** The MK61 features a larger diaphragm than a standard MK60 to provide even greater sensitivity and minimal offset from a required setpoint
- **MK60QC:** The MK60QC features a "Quick Change" dome for simple range spring replacements. Ideal for facilities with multiple pressure reducing applications - stock one valve with several spare springs to cover a wide range of needs
- **MK60H:** The MK60H features a handwheel that replaces the adjusting screw for easy changes to the setpoint
- **MK60HP:** The MK60HP is for higher pressure setpoints beyond the capability of a standard MK60
- **MK60GP:** The MK60GP option requires grain processing modification for starch cookers and other viscous services
- **MK601/602:** The MK601 and MK602 meet higher capacity requirements than standard regulators



MARK 60 FEATURES

- **Fast Response** — the short stroke means fast response to changes in process conditions, resulting in less offset in pressure.
- **Straight-through Flow** — The flow is straight through the valve seats and body. Direction of the disc travel is at right angles with the flow, not opposed to the direction of the flow. Thus, the flow does not unbalance the seats. The MK60 can use a wider range of its stroke to give accurate control; thereby giving a turndown ratio of approximately 15:1.
- **Quiet Operation** — The design of the Sliding Gate seats makes it inherently quieter than other types of regulators. The disc and plate are always in contact, which eliminates chattering. Straight-through flow minimizes turbulence. Multiple orifices in the plate and disc divide the flow stream into smaller flow components, also reducing noise.
- **Minimum Maintenance** — The MK60 sliding gate seats require no special tools for disassembly. The seats are pre-lapped at the factory and are self-lapping while in operation ensuring a continual tight shutoff. In sizes 2" (DN50) and below, there are no orings or gaskets to wear out - 100% metal-to-metal sealing - for longer service life.



Jordan Valve, a Division of Richards Industries
3170 Wasson Road • Cincinnati, Ohio 45209
Telephone 513-533-5600 • Fax 513-871-0105
Toll-Free Telephone: 800-543-7311 (U. S. A. & Canada)
E-Mail: info@richardsind.com • URL: www.jordanvalve.com

SPECIFICATIONS — MK60/60QC/61/60HP

Sizes: (note: 1/4" & 3/8" sizes use 1/2" body with reducers)

- Mark 60: 1/4" through 4" (DN8 through DN100)
- Mark 60QC: 1/4" through 2" (DN8 through DN50)
- Mark 61: 1/4" through 3/4" (DN8 through DN20)
- Mark 60HP: 1/4" through 4" (DN8 through DN100)

End Connections

- Threaded — FNPT, BSPT, BSPP (1/2" - 2" only, DN15-DN50)
- ANSI Flanges (150#, 300#)
- DIN Flanges (PN10/16, PN25/40)

Spring Housing

- CI or DI — 1/4" through 2" (DN8 through DN50)
- CI/Steel — 2-1/2" through 4" (DN65 through DN100)

Body Materials

- Ductile Iron
- Bronze (1/2" - 2", DN15-DN50)
- Carbon Steel (A216 WCB)
- Stainless Steel (A351/CF8M)

Trim Materials:

- 303SST — Standard on Ductile Iron, Bronze, Carbon Steel valves
- 316SST — Standard on Stainless Steel valves
- Monel, Hastelloy and other Alloys available

Reduced Pressure Control Ranges: Select a range to match your setpoint. For optimal performance, your setpoint should fall in the upper portion of the selected range.

Model	Size (DN)	Spring Ranges	
		PSI	BAR
60 & 60QC	1/4" - 3/4" (DN8 - DN20)	2 - 23	0,14 - 1,59
		10 - 38	0,69 - 2,62
		20 - 55	1,38 - 3,79
		35 - 160	2,41 - 11,03
		95 - 220	6,55 - 15,17
	1" - 2" (DN25 - DN50)	1 - 5	0,07 - 0,34
		3 - 8	0,21 - 0,55
		5 - 20	0,34 - 1,38
		10 - 30	0,69 - 2,07
		20 - 45	1,38 - 3,10
		30 - 95	2,07 - 6,55
	2-1/2" - 4" (DN65 - DN100)	60 - 160	4,14 - 11,03
		7 - 18	0,48 - 1,24
		10 - 25	0,69 - 1,72
		15 - 35	1,03 - 2,41
60HP	1/2" - 2" (DN15 - DN40)	50 - 150	3,45 - 10,34
		75 - 190	5,17 - 13,10
		100 - 320	6,89 - 22,06
		150 - 450	10,34 - 31,02
	2-1/2" - 4" (DN65 - DN100)	30 - 75	3,07 - 5,17
61	1/4" - 3/4" (DN8 - DN20)	65 - 110	4,48 - 7,58
		1 - 5	0,07 - 0,34
		2 - 12	0,14 - 0,83
		2 - 25	0,14 - 1,72
		10 - 35	0,69 - 2,41
		20 - 55	1,38 - 3,79
		20 - 80	1,38 - 5,52
		40 - 115	2,76 - 7,93
		25 - 160	1,72 - 11,03
		30 - 180	2,07 - 12,41

Seat Materials:

- Jorcote on SST — Standard
- Jorcote/Jordanic on SST — For Severe Service
- Other materials available — Consult Factory

Diaphragm Materials:

- Stainless Steel — Standard on 1/4" - 2" (DN8-DN50)
- Buna-N — Standard on 2-1/2" - 4" (DN65-DN100)
- Jorlon — On steam service 2-1/2" - 4" (DN65-DN100)
- Viton — Optional

Service: Steam, water, oil, gas, air and chemicals

Shutoff: ANSI Class IV

Options:

- **Double Bolting:** increases the pressure rating of the valve and ensures a tight seal between the spring housing and the body for services with high inlet pressures
- **High Pressure Spring Housing:** the HP option is an elongated spring housing that features a large spring for high pressure setpoints (up to 450 psi/31bar)
- **Handwheel:** the H option is a handwheel that is mounted on the adjusting screw to allow for easy setpoint changes
- **Exotic Alloys:** where service conditions dictate the use of specialty materials, the Mark 60 Series can be produced with bodies, trim and seats in Monel, Alloy 20, Hastelloy B, Hastelloy C, Titanium and others
- **GP Option:** grain processing modification for starch cookers and other viscous services. Available on Stainless Steel valves in 1/4" - 2" sizes only (DN8 - DN50)
- **Cryogenic Service:** CR option is a special spring housing for use if valve is in cryogenic conditions

CV Values & Maximum Differential Pressures

Cv (Kv)	Size (DN)	Seat Material	Maximum ΔP PSI (bar)
0.84 (0,74)	1/4" & 3/8" (DN8 & 12)	SST	125 (8,62)
1.6 (1,38)		Jorcote	400 (27,58)
2.5 (2,15)	1/2" & 3/4" (DN15 & 20)	SST	125 (8,62)
4.4 (3,78)		Jorcote	400 (27,58)
6.4 (5,50)	1" & 1-1/4" (DN25 & 32)	SST	125 (8,62)
9.5 (8,17)		Jorcote	400 (27,58)
15 (12,9)	1-1/2" (DN40)	SST	75 (5,17)
		Jorcote	325 (22,41)
25 (21,5)	2" (DN50)	SST	75 (5,17)
30 (25,8)		Jorcote	325 (22,41)
55 (47,3)	2-1/2" (DN65)	Jorcote	150 (10,34)
115 (98,9)	3" (DN80)	Jorcote	150 (10,34)
200 (172)	4" (DN100)	Jorcote	150 (10,34)

Low Flow Cv's: reduced Cv's (Kv's) are available. Cv (Kv) ratings of smaller sized valve can be supplied in a larger valve size

0.42 (0,36)	0.21 (0,18)	0.08 (0,07)	0.04 (0,03)	0.02 (0,02)
0.008 (0,007)	0.004 (0,003)	0.002 (0,002)	0.0008 (0,0007)	(N/A in 316SS)

MK60 SELF-OPERATING PRESSURE REGULATORS

Cv VERSUS OFFSET DATA

Model Mark 60 & 60QC									
Size NPS	Installed Cv	Set Pressure	Cv @ 5% Offset	Cv @ 10% Offset	Cv @ 15% Offset	CV @ 20% Offset	Cv @ 30% Offset		
1/4" - 3/4"	1.6	25	0.21	0.34	0.49	0.65	1.02		
		35	0.24	0.38	0.53	0.69	1.06		
		55	0.31	0.46	0.63	0.82	1.25		
		160	0.79	1.11	1.50	1.60	1.60		
		220	1.00	1.60	1.60	1.60	1.60		
	2.5	20	0.33	0.49	0.76	0.96	1.54		
		35	0.38	0.55	0.83	1.03	1.60		
		55	0.48	0.68	0.99	1.23	1.82		
		160	1.23	1.68	2.27	2.50	2.50		
		220	1.58	2.12	2.50	2.50	2.50		
	4.4	20	0.58	0.94	1.34	1.78	2.81		
		35	0.67	1.05	1.45	1.90	2.91		
		55	0.84	1.28	1.74	2.25	3.43		
		160	2.16	3.04	4.00	4.40	4.40		
1" - 1-1/4"	6.4	220	2.79	3.81	4.40	4.40	4.40		
		5	0.72	0.99	1.29	1.62	2.41		
		8	0.77	1.09	1.44	1.83	2.75		
		30	0.92	1.36	1.83	2.34	3.48		
		45	0.99	1.48	2.00	2.56	3.80		
		95	1.36	2.14	2.96	3.83	5.74		
	9.5	160	1.92	3.14	4.41	5.74	6.40		
		5	1.06	1.46	1.91	2.41	3.58		
		8	1.15	1.62	2.14	2.72	4.08		
		30	1.37	2.02	2.72	3.47	5.12		
		45	1.47	2.20	2.98	3.80	5.64		
		95	2.01	3.17	4.40	5.69	8.52		
		160	2.85	4.66	6.54	8.53	9.50		
		1-1/2"	15	5	1.55	2.11	2.72	3.40	5.02
8	1.67			2.32	3.03	3.82	5.69		
30	1.97			2.86	3.82	4.85	7.17		
45	2.10			3.10	4.16	5.30	7.81		
95	2.84			4.42	6.10	7.87	11.71		
160	3.98			6.44	9.02	11.73	15.00		
2"	25	5	2.86	3.95	5.15	6.50	9.70		
		8	3.09	4.37	5.79	8.21	11.07		
		30	3.69	5.46	7.37	9.42	14.04		
		45	3.96	5.95	8.07	10.33	15.34		
		95	5.45	8.60	11.94	15.47	23.20		
	30	160	7.74	12.65	17.81	23.2	25.00		
		5	3.11	4.21	5.43	6.79	10.04		
		8	3.34	4.64	6.06	7.65	11.39		
		30	3.93	5.72	7.64	9.70	14.34		
		45	4.20	6.20	8.33	10.60	15.62		
		95	5.69	8.85	12.19	15.73	23.48		
		160	7.97	12.89	18.04	23.45	30.00		
		2-1/4" - 4"	55	17	11.72	21.47	32.08	43.68	55.00
				25	10.92	19.67	29.08	39.23	55.00
35	9.83			17.31	25.22	33.59	51.92		
115	18		21.92	39.47	58.58	79.48	115.00		
	25		20.46	36.23	53.17	71.44	112.61		
	35		18.50	31.96	46.20	61.29	94.30		
200	18		34.71	61.53	90.74	122.68	196.40		
	25		32.47	56.57	82.47	110.39	173.29		
	35		29.48	20.05	71.81	94.85	145.29		

Notes:

1. Installed Cv is the Failure Cv for Safety Relief Valve Sizing
2. Assumes SST diaphragm, optimal spring range for set point, and minimum flow = 5% of Cv
3. Indicates valve reaches full Cv before offset is attained
4. Offset: also known as "droop", inaccuracy or deviation from setpoint is an inherent characteristic of self-operated regulators. Many factors affect and determine offset. Spring rate, diaphragm area and stroke length are three key factors. The short stroke of the SLIDING GATE design helps minimize droop. These tables can be used to estimate performance of the MK60 regulator.

Cv VERSUS OFFSET DATA

Model Mark 61							
Size NPS	Installed Cv	Set Pressure	Cv @ 5% Offset	Cv @ 10% Offset	Cv @ 15% Offset	CV @ 20% Offset	Cv @ 30% Offset
1/4" - 3/4"	1.6	5	0.23	0.33	0.44	0.56	0.86
		12	0.29	0.44	0.60	0.78	1.21
		25	0.36	0.56	0.78	1.03	1.60
		35	0.39	0.63	0.88	1.16	1.60
		55	0.44	0.71	1.00	1.31	1.60
		80	0.49	0.81	1.14	1.51	1.60
		115	0.56	0.92	1.30	1.60	1.60
		160	0.75	1.27	1.60	1.60	1.60
	180	0.79	1.33	1.60	1.60	1.60	
	2.5	5	0.36	0.51	0.69	0.88	1.34
		12	0.45	0.68	0.93	1.22	1.89
		25	0.56	0.87	1.22	1.61	2.50
		35	0.62	0.98	1.38	1.82	2.50
		55	0.68	1.10	1.56	2.05	2.50
		80	0.77	1.26	1.78	2.34	2.50
		115	0.87	1.44	2.03	2.50	2.50
		160	1.18	1.98	2.50	2.50	2.50
	180	1.24	2.07	2.50	2.50	2.50	
	4.4	5	0.63	0.90	1.21	1.55	2.35
		12	0.79	1.20	1.64	2.14	3.32
		25	0.98	1.54	2.15	2.83	4.40
		35	1.08	1.73	2.43	3.20	4.40
		55	1.21	1.94	2.74	3.61	4.40
		80	1.36	2.22	3.13	4.12	4.40
		115	1.54	2.53	3.57	4.40	4.40
		160	2.07	3.48	4.40	4.40	4.40
	180	2.18	3.65	4.40	4.40	4.40	

Notes:

1. Installed Cv is the Maximum Cv for Safety Relief Valve Sizing
2. Assumes SST diaphragm, optimal spring range for set point, and minimum flow = 5% of Cv
3. Indicates valve reaches full Cv before offset is attained

MAXIMUM WORKING PRESSURE, PSI

MAXIMUM WORKING PRESSURE, BAR

Temp °F	1/4" - 2"					
	DI Body			BRZ Body		
	150#	300#	TE	150#	300#	TE
-20 to 100	250	300 [600]	300 [600]	225	300 [500]	300 [500]
200	235	300 [600]	300 [600]	215	300 [475]	300 [475]
300	215	300 [565]	300 [600]	195	300 [425]	300 [425]
400	200	300 [525]	300 [600]	170	300 [375]	300 [375]
500	170	300 [495]	300 [600]	150	300 [325]	300 [325]
600	140	300 [465]	300 [600]	—	—	—
650	125	300 [450]	300 [600]	—	—	—

Temp °C	DN8 - DN50					
	DI Body			BRZ Body		
	150#	300#	TE	150#	300#	TE
-29 to 38	17	21 [41]	21 [41]	16	21 [34]	21 [34]
93	16	21 [41]	21 [41]	15	21 [33]	21 [33]
149	15	21 [39]	21 [41]	13	21 [29]	21 [29]
204	14	21 [36]	21 [41]	12	21 [26]	21 [26]
260	12	21 [34]	21 [41]	10	21 [22]	21 [22]
316	10	21 [32]	21 [41]	—	—	—
343	9	21 [31]	21 [41]	—	—	—

Temp °F	1/4" - 2"					
	CS Body			SS Body		
	150#	300#	TE	150#	300#	TE
-20 to 100	285	300 [740]	300 [950]	275	300 [720]	300 [950]
200	260	300 [675]	300 [950]	240	300 [620]	300 [950]
300	230	300 [655]	300 [950]	215	300 [560]	300 [950]
400	200	300 [635]	300 [950]	195	300 [515]	300 [950]
500	170	300 [600]	300 [950]	170	300 [480]	300 [950]
600	140	300 [550]	300 [950]	140	300 [450]	300 [905]
650	125	300 [535]	300 [950]	125	300 [445]	300 [890]

Temp °C	DN8 - DN50					
	CS Body			SS Body		
	150#	300#	TE	150#	300#	TE
-29 to 38	20	21 [51]	21 [66]	19	21 [49]	21 [66]
93	18	21 [47]	21 [66]	17	21 [43]	21 [66]
149	16	21 [45]	21 [66]	15	21 [39]	21 [66]
204	14	21 [44]	21 [66]	13	21 [36]	21 [66]
260	12	21 [41]	21 [66]	12	21 [33]	21 [66]
316	10	21 [38]	21 [66]	10	21 [31]	21 [62]
343	9	21 [37]	21 [66]	9	21 [31]	21 [61]

Temp °F	2-1/2" - 4"					
	DI Body		CS Body		SS Body	
	150#	300#	150#	300#	150#	300#
-20 to 100	250	500	285	500	275	500
200	235	500	260	500	240	500
300	215	500	230	500	215	500
400	200	500	200	500	195	500
500	170	495	170	500	170	500
600	140	300	140	300	140	300
650	125	300	125	300	125	300

Temp °C	DN65- DN100					
	DI Body		CS Body		SS Body	
	150#	300#	150#	300#	150#	300#
-29 to 38	17	34	20	34	19	34
93	16	34	18	34	17	34
149	15	34	16	34	15	34
204	4	34	14	34	13	34
260	12	34	12	34	12	34
316	10	21	10	21	10	21
343	9	21	9	21	9	21

Notes:

- 1 Double bolting option is required to reach pressures indicated in Brackets [].
- 2 If weld flanges are supplied, use ratings in "TE" column or flange rating, whichever is less (i.e. ANSI 600/900 flanges or PN64/100 flanges).
- 3 Consult factory for availability of ANSI/DIN/JIS flanges not indicated above.

DIMENSIONS — MK60/MK60QC

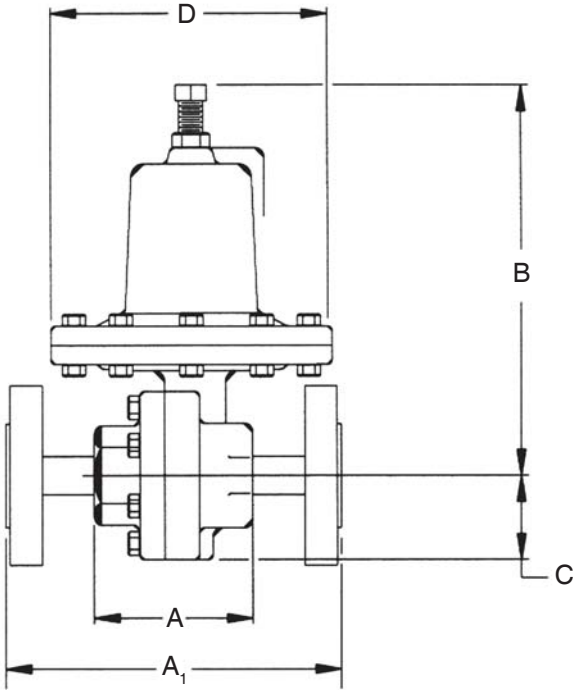

■ Mark 60/MK60QC*: Threaded & FSW Ends

Size	Material	A	B	B~QC	C	D	Weight (lbs)
1/2" & 3/4"	DI/BRZ	3.62"	8.50"	10.25"	1.69"	5.12"	10#
	CS/SS	3.62"	8.50"	10.25"	1.69"	5.12"	12#
1"	DI/BRZ	4.12"	10.00"	11.37"	2.62"	7.09"	21#
	CS/SS	4.18"	10.75"	12.00"	2.63"	7.09"	25#
1-1/4"	DI/BRZ	4.12"	10.00"	11.37"	2.62"	7.09"	21#
1-1/2"	DI/BRZ	4.50"	10.25"	11.37"	2.31"	7.09"	23#
	CS/SS	4.81"	11.00"	12.25"	2.25"	7.09"	31#
2"	DI/BRZ	4.50"	10.25"	11.37"	2.75"	7.09"	26#
	CS/SS	5.50"	11.00"	12.25"	2.75"	7.09"	35#

*For MK60QC, use Column B~QC

■ Mark 60/MK60QC: Threaded & FSW Ends, Metric

Size	Material	A	B	B~QC	C	D	Weight (kg)
DN15 & 20	DI/BRZ	91,95	215,90	260,35	42,93	130,05	4,5
	CS/SS	91,95	215,90	260,35	42,93	130,05	5,4
DN25	DI/BRZ	104,65	254,00	288,80	66,55	180,09	9,5
	CS/SS	106,17	273,05	304,80	66,55	180,09	11,3
DN32	DI/BRZ	104,65	254,00	288,80	66,55	180,09	9,5
	CS/SS	114,30	260,35	288,80	58,67	180,09	10,4
DN40	DI/BRZ	114,30	260,35	288,80	69,85	180,09	11,8
	CS/SS	122,17	279,40	311,15	57,15	180,09	14,1
DN50	DI/BRZ	114,30	260,35	288,80	69,85	180,09	11,8
	CS/SS	139,70	279,40	311,15	69,85	180,09	15,9

*For MK60QC, use Column B~QC

■ Mark 60: Integral Flanges: ANSI, CS & SS Bodies

Size	ANSI Flange	A1		B		C	D	Weight (lbs)	
		DI/BRZ	CS/SS	DI/BRZ	CS/SS	All	All	DI/BRZ	CS/SS
1/2"	150#	7.25	7.25	8.50	8.50	1.69	5.12	13	15
	300#	7.50	7.50	8.50	8.50	1.69	5.12	14	16
3/4"	150#	7.25	7.25	8.50	8.50	1.69	5.12	14	16
	300#	7.62	7.62	8.50	8.50	1.69	5.12	16	17
1"	150#	7.25 ¹	7.25 ²	10.00	10.75	2.62	7.09	26	34
	300#	8.75 ¹	7.75 ²	10.00	10.75	2.62	7.09	28	37
1-1/4"	150#	7.87	—	10.00	—	2.62	7.09	28	—
	300#	8.37	—	10.00	—	2.62	7.09	31	—
1-1/2"	150#	8.75 ¹	8.75 ²	10.25	11.22	2.31	7.09	42	46
	300#	10.25 ¹	9.25 ²	10.25	11.22	2.31	7.09	45	52
2"	150#	10.00	10.00	10.25	11.42	2.75	7.09	46	50
	300#	10.50	10.50	10.25	11.42	2.75	7.09	49	55

Note: dimensions for 2-1/2" - 4" sizes apply to DI bodies also.

1 Not ANSI standard 2 IFE only

■ Mark 60: Companion Flanges: ANSI, Ductile & Bronze Bodies

Size	Flange	A	B	C	D	Weight (lbs)
1/2"	150#	7.25"	8.50"	1.75"	5.12"	13#
	300#	7.50"	8.50"	1.87"	5.12"	14#
3/4"	150#	7.25"	8.50"	1.93"	5.12"	14#
	300#	7.62"	8.50"	2.31"	5.12"	16#
1"	150#	7.25"	10.00"	2.12"	7.09"	26#
	300#	8.75"	10.00"	2.43"	7.09"	28#
1-1/4"	150#	7.87"	10.00"	2.31"	7.09"	28#
	300#	8.37"	10.00"	2.62"	7.09"	31#
1-1/2"	150#	8.75"	10.25"	2.50"	7.09"	42#
	300#	10.25"	10.25"	3.06"	7.09"	45#
2"	150#	10.00"	10.25"	3.00"	7.09"	46#
	300#	10.50"	10.25"	3.25"	7.09"	49#

■ Mark 60: Flanged Ends, Metric

Size DN	Flange PN	Dimensions (mm)						Weight (kg)	
		A1*		B		C	D	DI/BRZ	CS/SS
		DI/BRZ	CS/SS	DI/BRZ	CS/SS	ALL	ALL		
15	10/16	184	130	216	240	43	130	5,9	6,8
	25/40	184	130	216	240	43	130	6,4	7,3
20	10/16	184	150	216	240	43	130	6,4	7,3
	25/40	184	150	216	240	43	130	7,3	7,7
25	10/16	184	160	273	262	67	180	11,8	15,4
	25/40	184	160	273	262	67	180	12,7	16,8
32	10/16	200	—	273	—	67	180	12,7	—
	25/40	200	—	273	—	67	180	14,1	—
40	10/16	222	200	279	285	59	180	19,1	20,9
	25/40	222	200	279	285	59	180	20,4	23,6
50	10/16	254	230	279	290	70	180	20,9	22,7
	25/40	254	230	279	290	70	180	22,2	24,9

FLANGED END CS/SS

Larger sizes	A1*	B	C	D	Weight (kg)	
65	10/16	283	476	177	324	75
	25/40	283	476	177	324	75
80	10/16	312	476	177	324	84
	25/40	312	476	177	324	84
100	10/16	350	507	203	324	98
	25/40	350	507	203	324	98

DIMENSIONS — MK60HP

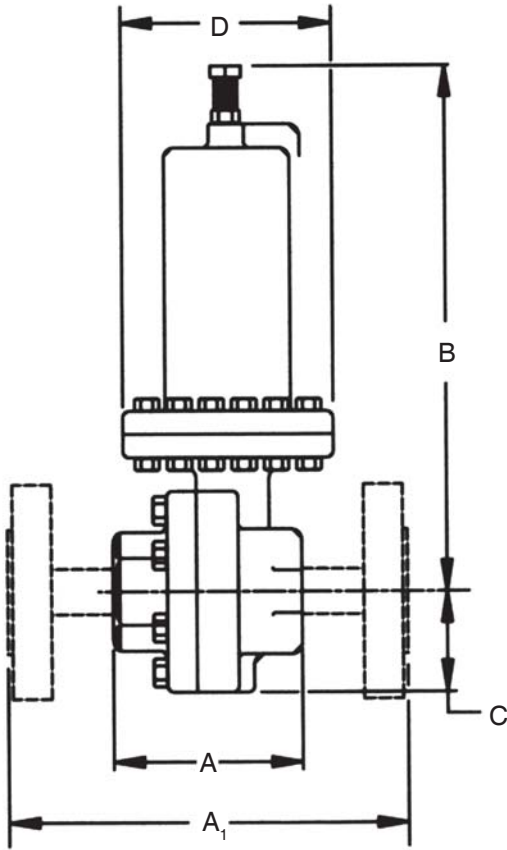

■ Mark 60HP: Flanged End

Size	Flange	A1		B •	C	D	Weight (lbs)
		DI/BRZ	CS/SS	All	All	All	All
1/2"	150#	7.25"	7.25"	12.25"	1.69"	5.20"	21 •
	300#	7.50"	7.50"	12.25"	1.69"	5.20"	
	• 600#	8.00"	8.00"	12.25"	1.69"	5.20"	
3/4"	150#	7.25"	7.25"	12.25"	1.69"	5.20"	22 •
	300#	7.62"	7.62"	12.25"	1.69"	5.20"	
	• 600#	8.12"	8.12"	12.25"	1.69"	5.20"	
1"	150#	7.25"	7.25"	12.75"	2.62"	5.20"	37
	300#	7.75"	7.75"	12.75"	2.62"	5.20"	
	• 600#	8.25"	8.25"	12.75"	2.62"	5.20"	
1-1/4"	150#	7.87"	—	12.75"	2.62"	5.20"	37
	300#	8.37"	—	12.75"	2.62"	5.20"	
1-1/2"	150#	8.75"	8.75"	13.25"	2.31"	5.20"	45
	300#	9.25"	9.25"	13.25"	2.31"	5.20"	
	• 600#	9.87"	9.87"	13.25"	2.31"	5.20"	
2"	150#	10.00"	10.00"	13.50"	2.75"	5.20"	49
	300#	10.50"	10.50"	13.50"	2.75"	5.20"	
	• 600#	11.25"	11.25"	13.50"	2.75"	5.20"	

- 600# are not IFE
- For IFE, add 1" (25,4mm) to all "B" dimensions

■ Mark 60HP: Flanged End, Metric³

Size DN	Flange PN	A1		B ²	C	D	Weight (kg)
		DI/BRZ ¹	CS/SS	All	All	All	All
15	10/16	184,15	130,00	311,15	42,93	132,08	9,5
	25/40	184,15	130,00	311,15	42,93	132,08	
20	10/16	184,15	150,00	311,15	42,93	132,08	10,0
	25/40	184,15	150,00	311,15	42,93	132,08	
25	10/16	184,15	160,00	323,85	66,55	132,08	16,8
	25/40	184,15	160,00	323,85	66,55	132,08	
32	10/16	199,90	—	323,85	66,55	132,08	16,8
	25/40	199,90	—	323,85	66,55	132,08	
40	10/16	222,25	200,00	336,55	58,67	132,08	20,4
	25/40	222,25	200,00	336,55	58,67	132,08	
50	10/16	254,00	230,00	342,90	69,85	132,08	22,2
	25/40	254,00	230,00	342,90	69,85	132,08	

- 1 Not IFE and not per DIN3202
- 2 For IFE, Add 25,4mm
- 3 For DIN flanges above PN40, please consult factory

■ Mark 60HP: Threaded & FSW Ends

Size	Material	A	B	C	D	Weight (lbs)
1/2" & 3/4"	DI/BRZ	3.62"	12.25"	1.75"	5.12"	15
	CS/SS	3.62"	12.25"	1.75"	5.12"	17
1"	DI/BRZ	4.12"	12.50"	2.12"	5.20"	21
	CS/SS	4.18"	12.75"	2.12"	5.20"	25
1-1/4"	DI/BRZ	4.12"	12.50"	2.12"	5.20"	21
1-1/2"	DI/BRZ	4.50"	12.75"	2.31"	5.20"	23
	CS/SS	4.81"	13.25"	2.50"	5.20"	31
2"	DI/BRZ	4.50"	12.75"	2.50"	5.20"	26
	CS/SS	5.50"	13.50"	2.50"	5.20"	35

■ Mark 60HP: Threaded & FSW Ends, Metric

Size	Material	A	B	C	D	Weight (kg)
DN15 & 20	DI/BRZ	91,95	311,15	44,45	130,05	6,8
	CS/SS	91,95	311,15	44,45	130,05	7,7
DN25	DI/BRZ	104,65	317,50	53,85	132,08	9,5
	CS/SS	106,17	323,85	53,85	132,08	11,3
DN32	DI/BRZ	104,65	317,50	53,85	132,08	9,5
DN40	DI/BRZ	114,30	323,85	58,67	132,08	10,4
	CS/SS	122,17	336,55	63,50	132,08	14,1
DN50	DI/BRZ	114,30	323,85	63,50	132,08	11,8
	CS/SS	139,70	342,90	63,50	132,08	15,9

DIMENSIONS — MK61

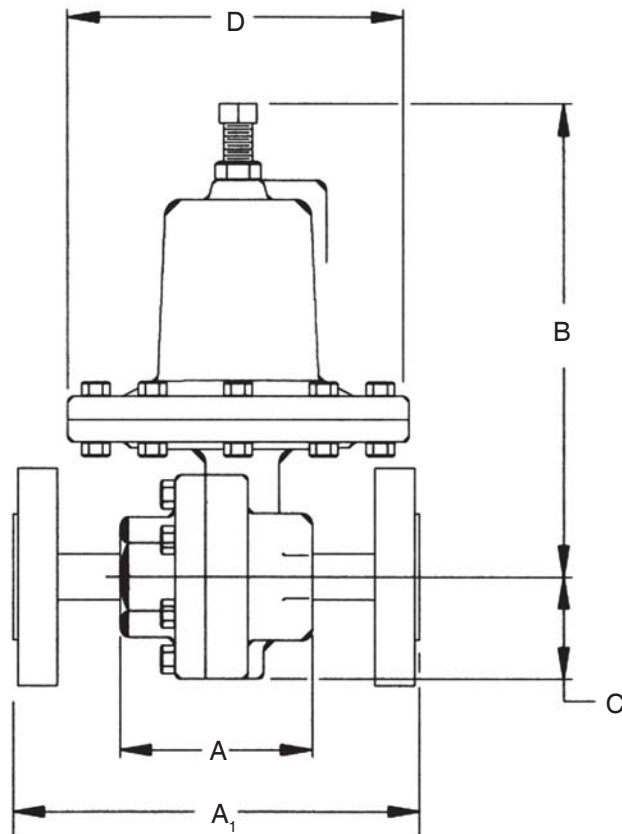

■ Mark 61: Threaded & FSW Ends

Size	Material	A	B	C	D	Weight (lbs)
1/2" & 3/4"	DI/BRZ	3.62	10.25	2.25	7.12	12
	CS/SS	3.62	10.25	2.25	7.12	13

■ Mark 61: Flanged Ends

Size	ANSI Flange	A1		B		C	D	Weight (lbs)	
		DI/BRZ	CS/SS	DI/BRZ	CS/SS	All	All	DI/BRZ	CS/SS
1/2 & 3/4"	150#	9.62	9.62	10.25	10.25	2.25	7.12	26	26
	300#	10.25	10.25	10.25	10.25	2.25	7.12	29	29

■ Mark 61: Threaded & FSW Ends, Metric

Size	Material	A	B	C	D	Weight (kg)
DN15 & 20	DI/BRZ	91,95	260,35	57,15	180,85	5,4
	CS/SS	91,95	260,35	57,15	180,85	5,9

■ Mark 61: Flanged Ends, Metric

Size DN	Flange PN	A1 ¹		B		C	D	Weight (kg)	
		DI/BRZ	CS/SS	DI/BRZ	CS/SS	All	All	DI/BRZ	CS/SS
15 & 20	10/16	244,4	244,4	260,4	260,4	57,2	180,9	11,8	11,8
	25/40	260,4	260,4	260,4	260,4	57,2	180,9	13,2	13,2

Note: 1/4" & 3/8" utilize 1/2" body with reducer bushings

¹ Not per DIN3202

MK60 SELF-OPERATED PRESSURE REGULATORS

ORDERING SCHEMATIC

1	-	2	-	3	/	4	5	6	7	8	9	10
---	---	---	---	---	---	---	---	---	---	---	---	----

1	Model	
	60	Standard
	60HP	High Pressure
	60QC	Quick Change
	61	Large Diaphragm

2	Size		
		Inches	DN
	025	1/4"	DN8
	038	3/8"	DN10
	050	1/2"	DN15
	075	3/4"	DN20
	100	1"	DN25
	125	1-1/4"	DN32
	150	1-1/2"	DN40
	200	2"	DN50
	250	2-1/2" (MK60/60HP only)	DN65
	300	3" (MK60/60HP only)	DN80
	400	4" (MK60/60HP only)	DN100

MK61 available in 1/4" through 3/4" only

3	Body Material	
	DI	Ductile Iron
	BR	Bronze (1/4" - 2")
	CS	Carbon Steel
	S6	Stainless Steel
	CI	Cast Iron (2-1/2" - 4")

4	End Connections	
	1-4" - 2" MK60/61	
	PT	NPT
	BT	BSPT
	BP	BSPP
	SW	FSW
	I5	150# IFE
	F5	150# FE (Except IFE)
	I3	300# IFE
	F3	300# FE (Except IFE)
	2-1/2" - 4" MK60	
	I1	125# IFE
	I5	150# IFE
	I2	250# IFE
	I3	300# IFE
	I7	PN 10 DIN IFE (CS/S6) DN15-150
	I6	PN 16 DIN IFE (CS/S6) DN15-150
	I8	PN 25 DIN IFE (CS/S6) DN15-150
	I4	PN 40 DIN IFE (CS/S6) DN15-150

5	Trim	
	S3	303SS
	S6	316SS
	I3	303SSF/IFE (1" - 2")
	I6	316SSF/IFE (1" - 2")

6	Seat Material	
	A	303SST (1/4" - 2")
	B	316SST (1/4" - 2")
	V	303SS/Jorcote
	W	316SS/Jorcote
	X	303SS/JOR/JIC
	Y	316SS/JOR/JIC

7	Cv (Kv)			
	1	0.21 (0,28)	9	15 (12,93)
	2	0.42 (0,36)	A	25 (21,55)
	3	0.84 (0,72)	B	30 (25,86)
	4	1.6 (1,38)	D*	55 (47,41)
	5	2.5 (2,16)	F*	85 (73,28)
	6	4.4 (3,79)	G*	115 (99,14)
	7	6.4 (5,52)	I*	200 (172,41)
	8	9.5 (8,19)	* 2-12" - 4" only	

8	MK60 Spring Range PSI (BAR)					
	1/4" - 3/4"		1" - 2"		2-1/2" - 4"	
	16	2-23 (0,14-1,6)	05	1-5 (0,07-0,34)	29	7-18 (0,48-1)
	37	10-38 (0,69-3)	20	3-8 (0,21-5,5)	32	10-25 (0,69-2)
	56	20-55 (1-4)	28	5-20 (0,34-1)	42	15-35 (1-2)
	81	35-160 (2-11)	34	10-30 (0,69-2)		
	A6	95-220 (7-15)	53	20-45 (1-3)		
			75	30-95 (2-7)		
			97	60-160 (4-11)		

8	MK60HP Spring Range PSI (BAR)			
	1/2" - 2"		2-1/2" - 4"	
	A1	75-190 (5-13)	71	30-75 (3-5)
	A7	100-320 (7-220)	98	65-110 (4-8)
	A9	150-450 (10-31)		

8	MK61 Spring Range PSI (BAR)			
	05	1-5 (0,07-0,34)	63	20-80 (1-6)
	10	2-12 (0,14-0,83)	87	40-115 (3-8)
	17	2-25 (0,14-2)	70	25-160 (2-11)
	36	10-35 (0,69-2)	80	30-180 (2-12)
	56	20-55 (1-4)		

9	Diaphragm	
	S6	316 SST (1/4" - 2" only)
	V1	Viton
	BN	Buna-N (standard above 2"/DN50)
	JL	Jorlon

10	Actuator	
	MD	for Metal Diaphragm (1/4" - 2" only)
	ED	for Elastomer Diaphragm

Mark 601/602 Series

High Flow Pressure Regulators

The Mark 601 and 602 meet higher capacity requirements than standard regulators. The High Flow Mark 601 has Cv's as high as 50 (43Kv) and the Super High Flow Mark 602 has Cv's up to 70 (60,2 Kv). Each valve is standard with Jordan's Sliding Gate Seats, which helps to reduce the droop commonly associated with high flow regulators.

Jordan's unique self-operated sliding gate pressure regulator offers:

- Shorter stroke than a globe or plug-style valve
 - Faster response
 - Less offset
 - Smaller and lighter weight than globe-style valves
 - Longer diaphragm life
- Straightthrough -flow
 - Less turbulence, erosion and noise
 - Improved rangeability
 - Longer seat life
- Ease of maintenance
 - Interchangeable seats and Cv's
 - Fewer spare parts
 - Self-cleaning seats
 - No gaskets or o-rings



Diaphragm Materials

- Stainless Steel — standard
- Buna-N — optional
- Jorlon — optional
- Viton — optional

Service: Steam, water, oil, gas, air and chemicals

Shutoff: ANSI Class IV

Reduced Pressure Control Ranges: Select a range to match your setpoint. For optimal performance, your setpoint should fall in the upper portion of the selected range.

SPECIFICATIONS

Sizes: 1-1/2" & 2" (DN40 & DN50)

End Connections

- Threaded (NPT, BSPT, BSPP)
- ANSI Flanges (150#, 300#)
- DIN Flanges (PN10/16, PN25/40)

Body Materials

- Ductile Iron
- Bronze
- Carbon Steel (A216 WCB)
- Stainless Steel (A351/CF8M)

Trim Materials

- 303SST — Standard on Ductile Iron, Bronze, Carbon Steel valves
- 316SST — Standard on Stainless Steel Valves
- Monel, Hastelloy and other Alloys available

Seat Materials

- Jorcote on SST — Standard
- Jorcote/Jordanic on SST — For Severe Service

Model	Size (DN)	Spring Ranges	
		PSI	BAR
601 & 602	1-1/2" - 2" (DN40 - DN50)	20 - 45	1,72 - 3,10
		30 - 95	2,07 - 6,55
		60 - 160	4,14 - 11,03

Cv Values & Maximum Differential Pressures

- Mark 601

Cv (Kv)	Size (DN)	Seat Material	Maximum ΔP PSI (bar)
25 (21,5)	1-1/2" & 2" (DN40 & DN50)	Jorcote	150 (10,34)
30 (25,8)	1-1/2" & 2" (DN40 & DN50)	Jorcote	150 (10,34)
35 (30,1)	1-1/2" & 2" (DN40 & DN50)	Jorcote	150 (10,34)
45 (38,7)	1-1/2" & 2" (DN40 & DN50)	Jorcote	150 (10,34)
50 (43,0)	1-1/2" & 2" (DN40 & DN50)	Jorcote	150 (10,34)

- Mark 602

Cv (Kv)	Size (DN)	Seat Material	Maximum ΔP PSI (bar)
65 (55,9)	1-1/2" (DN40)	Jorcote	150 (10,34)
70 (60,2)	2" (DN50)	Jorcote	150 (10,34)

DIMENSIONS

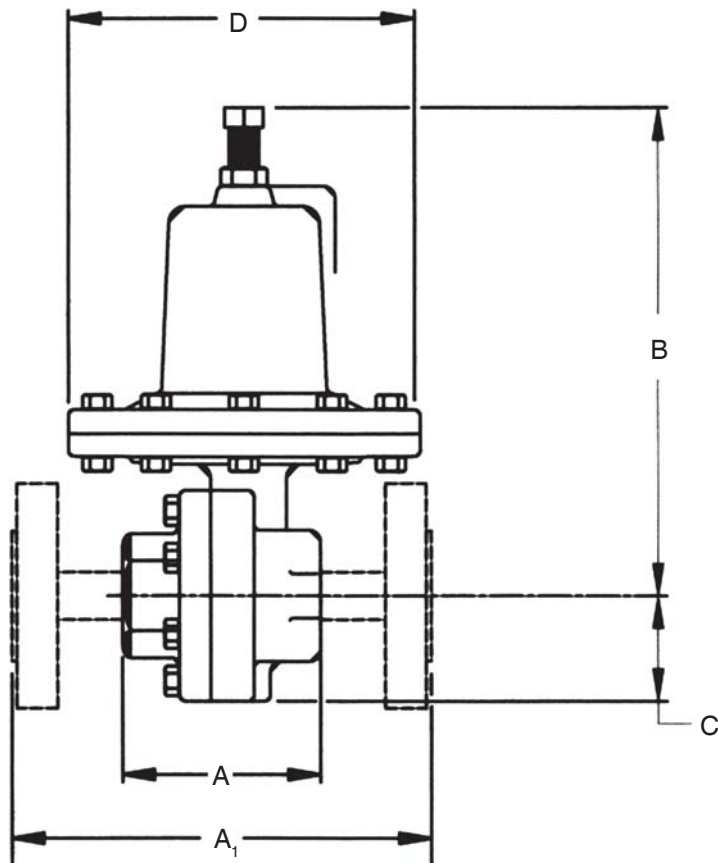

■ Mark 601/602: Threaded & FSW Ends

Size	Material	A	B	C	D	Weight (lbs)
1-1/2" - 2"	DI/BRZ	4.50	10.25	2.75	7.09	26
	CS/SS	5.50	11.00	2.75	7.09	35

■ Mark 601/602: Threaded & FSW Ends, Metric

Size	Material	A	B	C	D	Weight (kg)
DN40- DN50	DI/BRZ	114,3	260,4	69,9	180,1	11,8
	CS/SS	139,7	279,4	69,9	180,1	15,9

■ Mark 601/602: Flanged Ends

Size	ANSI Flange	A1		B		C	D	Weight (lbs)	
		DI/BRZ	CS/SS	DI/BRZ	CS/SS			All	All
1-1/2"	150#	10.00*	10.00*	10.25	11.22	2.31	7.09	42	46
	300#	10.25*	10.25*	10.25	11.22	2.31	7.09	45	52
2"	150#	10.00	10.00	10.25	11.42	2.75	7.09	46	50
	300#	10.50	10.50	10.25	11.42	2.75	7.09	49	55

- Not IFE
- Not ANSI Standard

■ Mark 601/602: Flanged Ends, Metric

Size	Flange PN	A1*		B		C	D	Weight (kg)	
		DI/BRZ	CS/SS	DI/BRZ	CS/SS			All	All
DN40	10/16	254,0*	254,0*	279,0	285,0	58,7	180,1	19,1	20,9
	25/40	260,4*	260,4*	279,0	285,0	58,7	180,1	20,4	23,6
DN50	10/16	254,0	230,0	279,0	290,1	69,9	180,1	20,9	22,7
	25/40	266,7	230,0	279,0	290,1	69,9	180,1	22,2	24,9

- Not IFE
- Not per DIN3202

ORDERING SCHEMATIC

1	—	2	—	3	/	4	5	6	7	8	9	10	11	12

1	Model	
	601	High Flow
	602	Super High Flow

2	Size		
		Inches	DN
	150	1-1/2"	DN40
	200	2"	DN50

3	Body Material	
	DI	Ductile Iron
	BR	Bronze
	CS	Carbon Steel
	S6	Stainless Steel

4	End Connections	
	PT	NPT
	BT	BSPT
	I5	150# IFE CS or SST*
	F5	150# FE DI or BR
	I7	PN10 IFE, CS or SST*
	F7	PN10 FE DI or BR
	I6	PN16 IFE, CS or SST*
	F6	PN16 FE DI or BR
	BP	BSPP
	SW	FSW
	I3	300# IFE, CS or SST*
	F3	300# FE DI or BR
	I8	PN25 IFE, CS or SST*
	F8	PN25 FE DI or BR
	I4	PN40 IFE, CS or SST*
	F4	PN40 FE DI or BR

* IFE for 2" only

5	Trim	
	S3	303SS
	S6	316SS
	I3	303SSF/IFE
	I6	316SSF/IFE

6	Seat Material	
	V	303SS/Jorcote
	W	316SS/Jorcote
	X	303SS/JOR/JIC
	Y	316SS/JOR/JIC

7	CV (Kv)	
	A	25 (22)
	B	30 (26)
	V	35 (30)
	W	45 (39)
	C	50 (43)
	Y	65 (56)
	E	70 (60)

8	Range	
	53	20-45 (1,38-3,01)
	75	30-95 (2,07-6,55)
	97	60-160 (4,14-11,03)

9	Diaphragm	
	S6	316 SST
	V1	Viton
	BN	Buna-N
	JL	Jorlon

10	Actuator	
	MD	for Metal Diaphragm
	ED	for Elastomer Diaphragm

11	Double Bolting	
	00	None
	ZZ	Non-Standard

12	Accessories	
	0	None
	6	316 SS Bolting
	7	Hi-temperature bolting
	Z	Non-standard