



Style B3 900

WCB/LCC - 2220 PSI
CF8M - 2160 PSI

Product Features

- Bolted 3 Piece Construction
- Swing Out Body Design
- Fully Enclosed Body Bolts
- Full Port
- NPT or SW End Connections
- ASME B16.34
- NACE MR0175-2002
- Blow Out Proof Stem
- Locking Device
- Dual Stem Seal

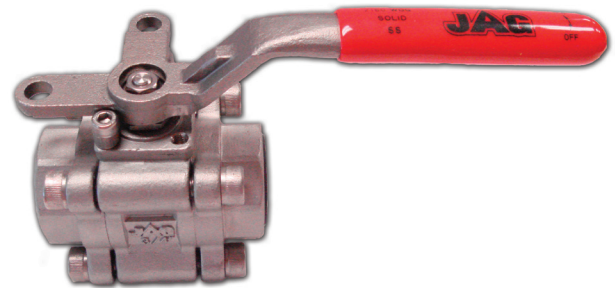

NO.	PARTS	STD	NACE	LOW TEMP NACE	SS	QTY
1	BODY	WCB	WCB	LCC	CF8M	1
2	CAP	WCB	WCB	LCC	CF8M	2
3	GASKET	GRAPHITE	GRAPHITE	GRAPHITE	GRAPHITE	2
4	O-RING	NBR	VITON	VITON	VITON	2
5	SEAT	RTFE	RTFE	RTFE	RTFE	2
6	BALL	CF8	CF8M	CF8M	CF8M	1
7	STEM	316	316	316	316	1
8	THRUST WASHER	RTFE	RTFE	RTFE	RTFE	1
9	O-RING	NBR	VITON	VITON	VITON	1
10	PACKING	GRAPHITE	GRAPHITE	GRAPHITE	GRAPHITE	1
11	GLAND	304	304	304	304	1
12	WASHER	304	304	304	304	2
13	BOLT	A2-70	A2-70	A2-70	A2-70	2
14	STEM NUT	C/S P	C/S P	C/S P	304	1
15	CAP SCREW	A193-B7	A193-B7M	A320-L7M	A193-B8	8
16	HANDLE	WCB	WCB	WCB	CF8	1
17	GRIP	PLASTIC	PLASTIC	PLASTIC	PLASTIC	1

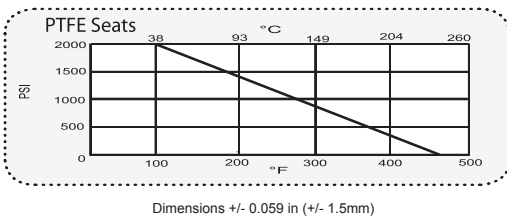
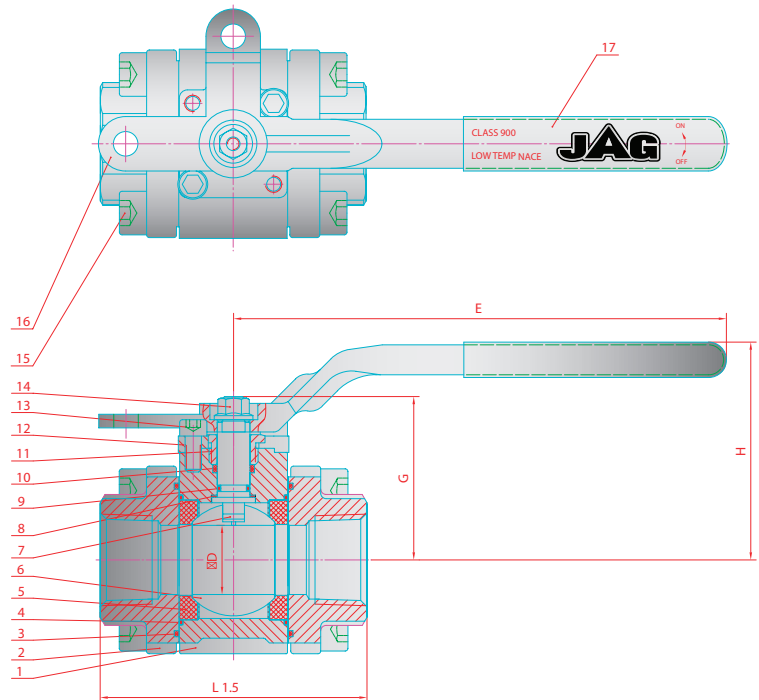

Size		D		L		H		E		G	
in	mm	in	mm	in	mm	in	mm	in	mm	in	mm
1/4"	6.4	0.5	12.7	2.9	73	2.7	68	5.9	150	1.8	46.5
3/8"	9.5	0.5	12.7	2.9	73	2.7	68	5.9	150	1.8	46.5
1/2"	12.7	0.5	12.7	2.9	73	2.7	68	5.9	150	1.8	46.5
3/4"	19.1	0.75	19.05	3	78	2.9	72.5	5.9	150	2	51
1"	25.4	1	25.4	3.8	98	3	76	7.1	180	2.4	60
1 1/4"	32	1.5	38	4.8	122	3.9	98.5	9.3	237	3.2	81
1 1/2"	38.1	1.5	38	5.4	137	3.9	98.5	9.3	237	3.2	81
2"	50.8	2	50	5.8	148	4.2	107.5	9.3	237	3.5	90

We reserve the right to modify dimensions or materials.

JAG flocomponents LP

8440 Roper Road
 Edmonton, Alberta T6E 6W4
 Tel: 780-485-2333 Fax: 780-485-2316

PRINTED IN CANADA
 08/03/2006 QTY1000

CAN B38-1205

