



FLOW SAFE, Inc.

"Environmental Performance for Industry"



F70 PR Series

Pilot-Operated Pressure Relief Valves

CONTENTS

SECTION	PAGES
<u>CONTENTS & INTRODUCTION</u>	2
<u>OPERATION</u>	3
<u>APPLICATIONS</u>	
● Natural Gas	4
● Process Industries	5
● Positive Displacement Blower Packages	5
<u>ENGINEERING DATA</u>	
● Construction	
-Main Valve Assemblies	
High Pressure	6-7
Low Pressure	8-9
-Pilot Valve Assemblies	10
● Accessories	11
● Sizing Formulas	12
● Flow Capacities	13
● Specifications	14
● Dimensions & Weights	14
● How to Order &	
Part Numbers	15
● Other FLOW SAFE	
Products	16

The policy of FLOW SAFE and its authorized assemblers is a commitment to value through:

- Environmentally Compatible Products
- Cost Efficient Design, with minimal parts
- Quality Products, Readily Available
- Flexibility, to meet Unique Customer Needs
- "No Hassle" Service

INTRODUCTION

Today's Natural Gas and Process Industries require leaktight valves to reduce emissions, save product, and minimize horsepower requirements.

The **F7OPR** Series "High Performance" Pilot Operated pressure relief valves accomplish bubble-tight sealing with accurate and consistent operational characteristics.

F7OPR design features include:

- MODULATING VALVE ACTION
 -"LESS PRODUCT LOSS"
- ELASTOMERIC SEAT & SEALS
- REPEATABLE BUBBLE-TIGHT SEATING
- RUGGED, SIMPLE, & EFFICIENT DESIGN
- SUPERIOR FLOW CAPACITIES
- 10"WC to 285 psig PRESSURE RANGE
- -65 to +400°F SERVICE TEMPERATURE RANGE
- EASY & ECONOMICAL INSTALLATION
- INLINE MAINTENANCE CAPABILITY
- PILOT EXHAUST TO MAIN VALVE - STANDARD
- CAPACITIES *INDEPENDENTLY* VERIFIED
- DISCHARGE DRAIN PLUG STANDARD
- LIFT BRACKETS-2x3 AND LARGER - STANDARD
- LOW UPSET RATIO (Piston Area/Seat Area)
- DOT COMPLIANCY

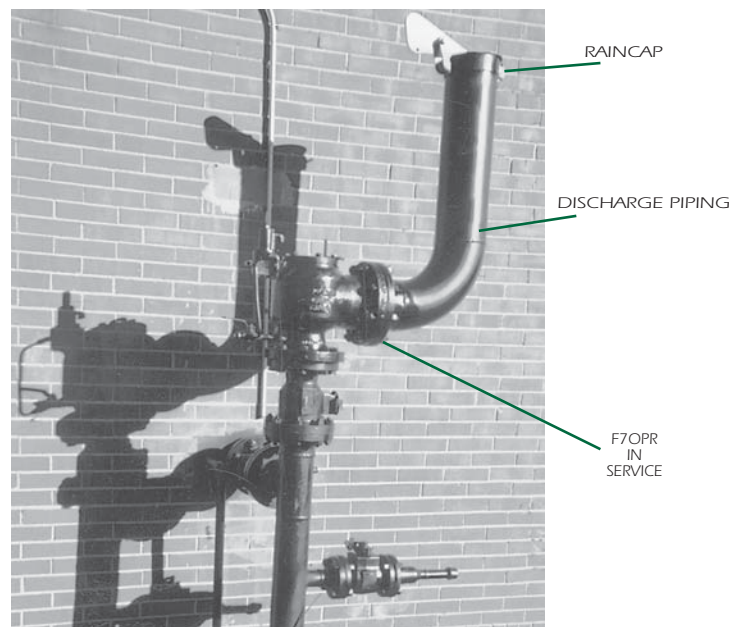

OPERATION

F70PR SERIES

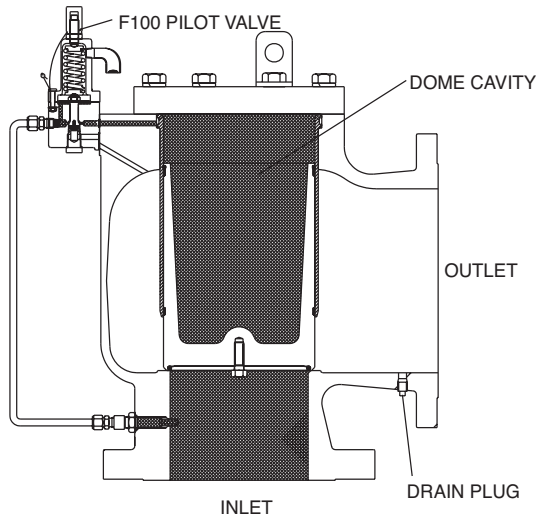

CLOSED

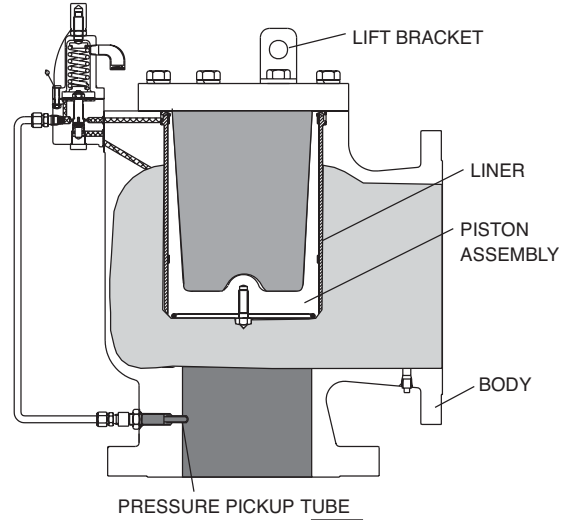

OPEN

- INLET PRESSURE
- DOME PRESSURE
- OUTLET PRESSURE
- UNPRESSURIZED

System pressure is routed from the inlet below the valve, through a modulating pilot valve to the dome cavity of the valve. At the designated set pressure, the pilot valve reduces the dome pressure, proportional to demand at the set pressure, and allows the piston to go into lift. Once system pressure is relieved, the pilot valve closes, allowing the dome to repressurize and the main valve piston to close.

When closed, dome pressure acting on a differential area between the top and bottom of the piston assembly, creates a downward force on the seat providing bubble-tight shutoff.

The **F70PR** utilizes an elastomeric seat on the piston to achieve bubble-tight seating. A dynamic piston seal prevents any leakage from the dome to the discharge. Guide rings on the piston prevent any metal-to-metal contact, and help to provide smooth, consistent, and repeatable operation.

F100 LOW PRESSURE ASSEMBLY
(10" WC - 5 psig)

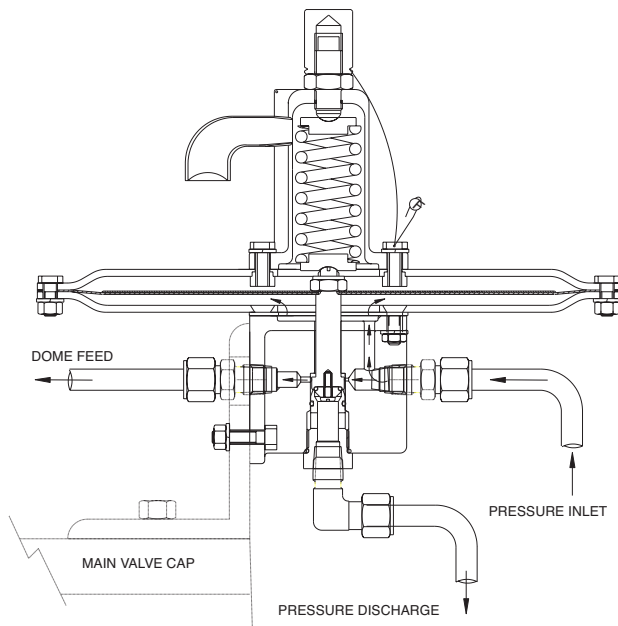

F100 HIGH PRESSURE ASSEMBLY
(5 - 285 psig)

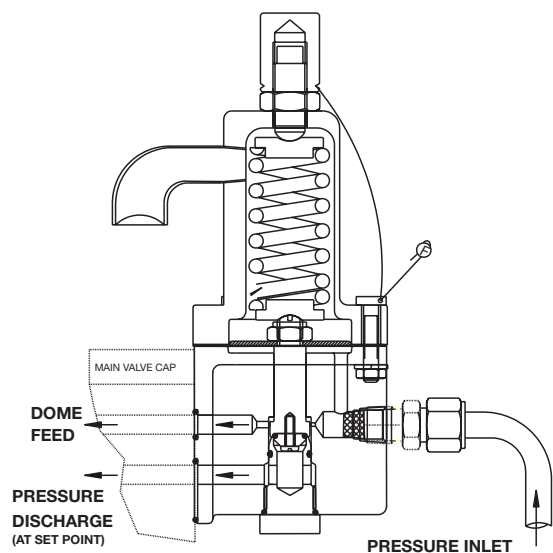

Natural Gas

The **F70PR** Pressure Relief Valve provides overpressure safety protection for natural gas distribution or transmission applications, with the ability to handle large volumes and provide consistent, bubble-tight shutoff before and after a system upset.

The **F70PR** is designed to be repeatedly cycled at full pressure throughout its acceptable range of temperatures. It is ideal for systems that require overpressure protection, and utilizes modulating action to improve process efficiency and reduce product loss. The **F70PR's** 100 Series pilot valve is bubble-tight to the set point upon opening, and to 95% of the set point upon closure, allowing the user to operate close to the nameplate set pressure. A maximum of 10% overpressure is required to fully open the valve.

Ideal for Gas Regulator or Meter protection. Pressure spikes between the regulator and pressure relief valve can be handled using the **F70PR's** modulating pilot feature.

This can minimize regulator-to-pressure relief valve cycle conflict.

These valves are particularly advantageous and cost effective in installations where:

- There may be size and weight limitations for the valve
- A high cycling rate exists
- A long service life is required
- Minimal product loss is important
- Reduced maintenance and installation time is desirable
- DOT Compliancy is required

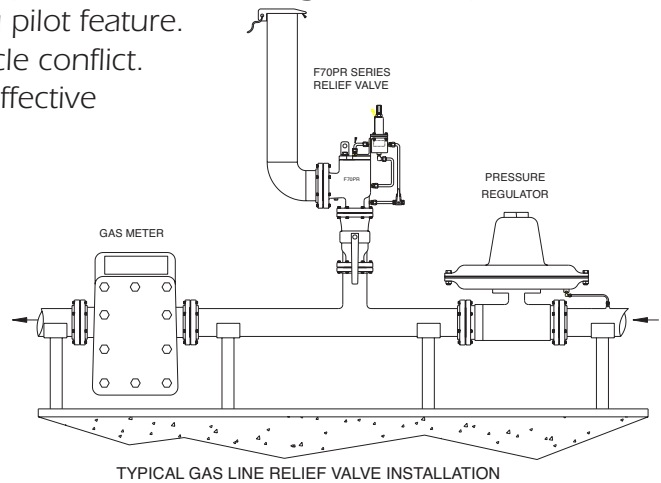

In all applications, consideration should be given by the end user to prevent freezing of liquids within the valve, which may under certain conditions cause erratic performance or valve failure.

COMPARE THE VALUE!

Value of Ownership is offered by utilizing the **F70PR**. Easy installation and inline maintenance is offered by the right angle body style design.

High flow rates provide, in many cases, one inlet size smaller than equivalent flow capacity pilot operated regulator/relief valves.

The FLOW SAFE **F70PR** features:

- Simple Design
- Reliable Operation
- Easy Installation
- Easy, Inline Servicibility
- Superior Flow Capacities
- Easy Field Testing
- E.S.D. - Emergency Shutdown

Capability available with use of dome unloader option (See Page 11).

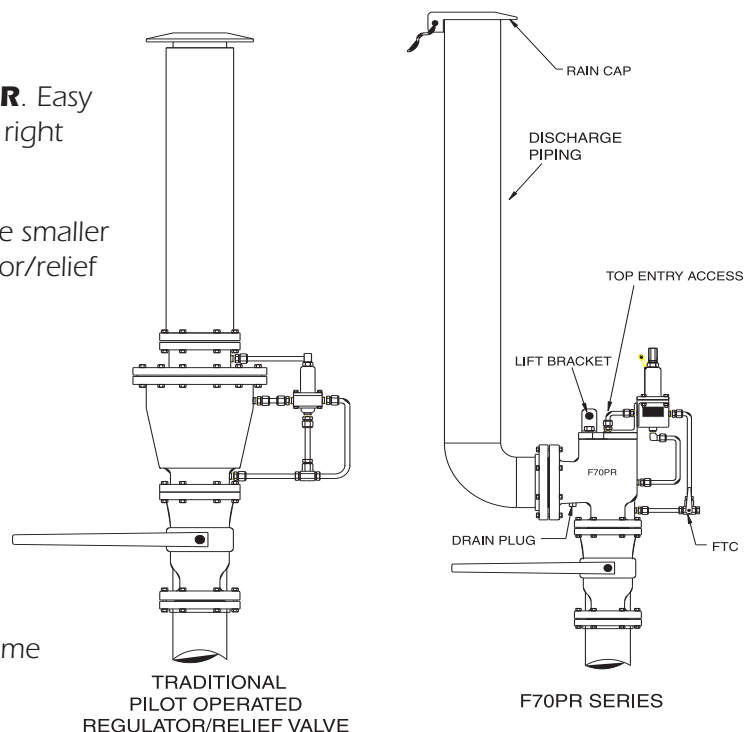

Process Industries

The **F70PR** Pressure Relief Valve is a superior choice to protect industrial process applications because of the valve's heavy duty, low profile body design.

The **F70PR's** ability to flow high volumes of gas or liquid allows for a smaller valve size than traditional relief valves to get the job done. Smaller valves are not only less expensive but also require smaller piping and isolation valving, and the associated connections, both on the inlet and on the outlet.

The integral, "No leak" nozzle design provides for fewer leak points and helps process operators to obtain insurance credits and lower rates.

Remote pressure pickup, unloading, field testing are available options for the **F70PR** Series that allow the operator greater versatility in the operation and servicing of this valve. See page 11 for more details.

Positive Displacement Blowers-Relief and Unloading

The design technology of the **F70PR** offers, for the first time, a solution for this very demanding, high cycle, high vibration/pulsation service. Due to the robust piston design, the **F70PR** can handle the inherent vibrations and pulsations of these blower systems. The welded-in stainless steel seating surface, the piston guide rings, and the high L/D piston construction allow the valve the ability to operate reliably and for an extended period of time.

The installation of a solenoid valve to the dome of the **F70PR** main valve allows unloading by using the relief valve (two valves in one). Upon startup, to reduce downstream load the unloaded **F70PR** provides atmospheric reference. When the blower stage is run, the **F70PR** reverts back to the relief mode.

By unloading upon startup, less load is applied to motors offering protection, extending motor life, and in some cases reducing the required motor horsepower. Expensive butterfly valves and high maintenance actuators can be avoided when replaced with the **F70PR** Relief and Unloader.

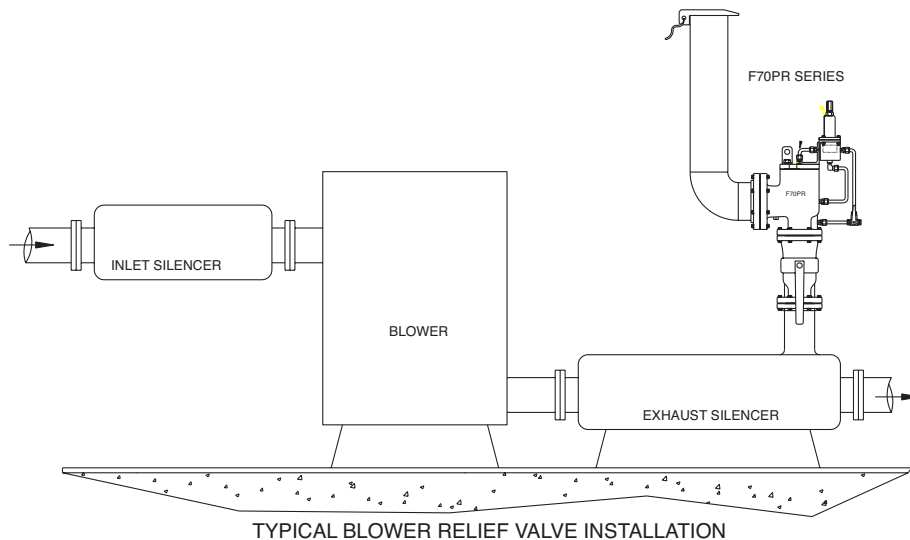

CONSTRUCTION F70PR HIGH PRESSURE ASSEMBLY

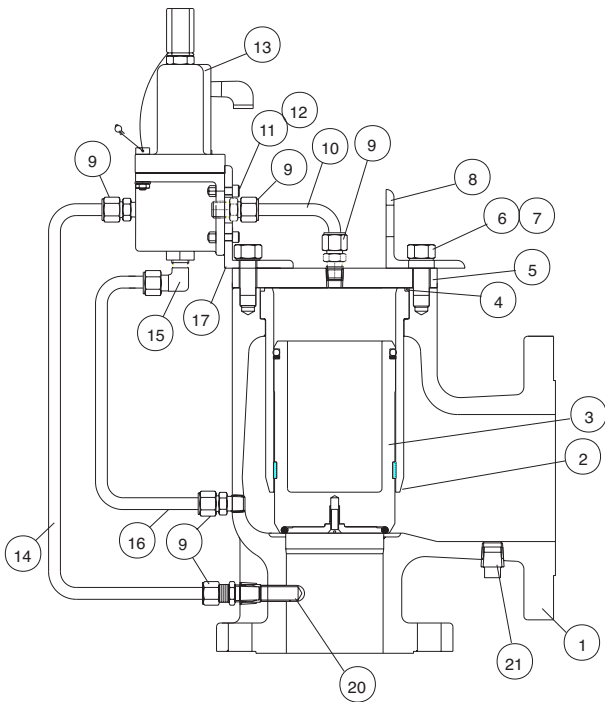

F70PR HIGH PRESSURE ASSEMBLY
(SIZES 2x3 & 3x4)

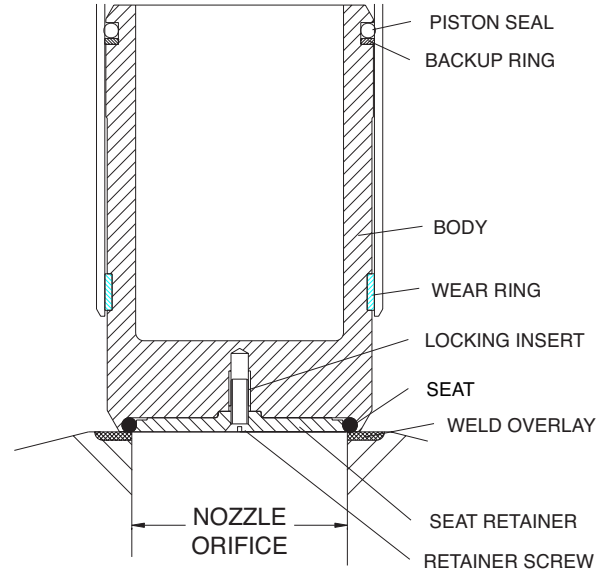

HIGH PRESSURE PISTON ASSEMBLY
(SIZES 2x3 & 3x4)

PRESSURE RANGE
<ul style="list-style-type: none"> • 5-285 psig, with F100 High Pressure Pilot Valve • Full Lift within 10% above Set Pressure

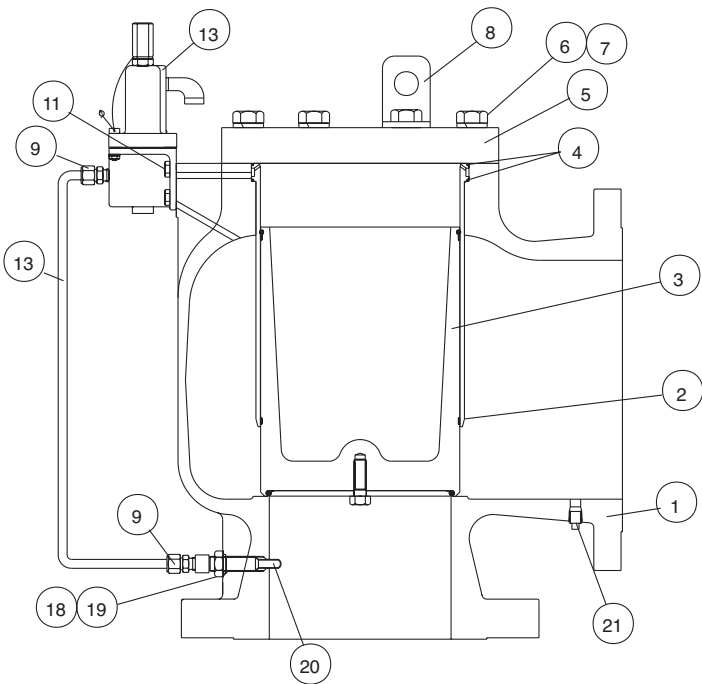

F70PR HIGH PRESSURE ASSEMBLY
(SIZES 4x6 THROUGH 12x16)

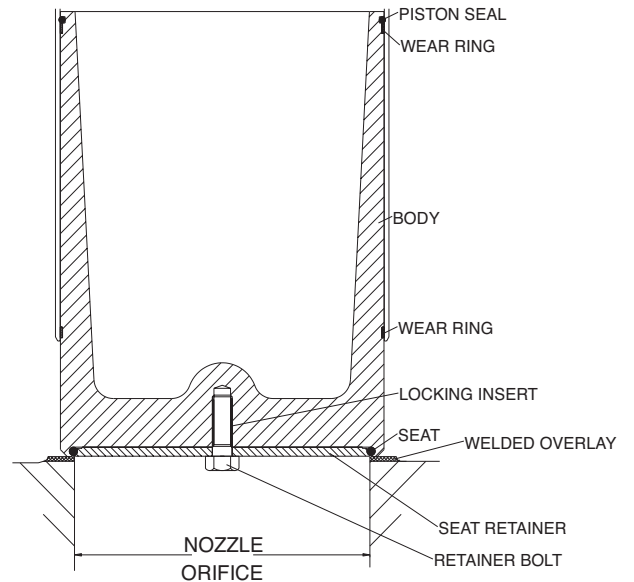

HIGH PRESSURE PISTON ASSEMBLY
(SIZES 4x6 THROUGH 12x16)

PRESSURE RANGE
<ul style="list-style-type: none"> • 5-285 psig, with F100 High Pressure Pilot Valve • 2- 5 psig, with F100 Low Pressure Pilot Valve • Full Lift within 10% above Set Pressure

CONSTRUCTION F70PR HIGH PRESSURE ASSEMBLY

Item No.	Description	Materials of Construction	
		Standard	Standard/S1 Trim
1	Body	Carbon Steel(A-216 Gr WCB) ¹	Carbon Steel (A-216 Gr WCB) ¹
2	Liner	Carbon Steel/Plated ¹	Carbon Steel/Plated ¹
3	Piston Assembly (High Pressure)	Aluminum (6061)	Stainless Steel (304SS)
4	Seal ²	Buna-N Elastomer ²	Buna-N Elastomer ²
5	Cap	Carbon Steel ¹	Carbon Steel ¹
6	Cap Bolt	Carbon Steel/Plated	Carbon Steel/Plated
7	Washer	Carbon Steel/Plated	Stainless Steel
8	Lift Bracket (Sizes 2x3 & larger)	Carbon Steel	Carbon Steel
9	Straight Fitting	Stainless Steel	Stainless Steel
10	Dome Tube	Stainless Steel	Stainless Steel
11	Bolt	Stainless Steel	Stainless Steel
12	Nut	Stainless Steel	Stainless Steel
13	F100 High Pressure Pilot Valve	Aluminum/Stainless Steel Trim ³	Aluminum/Stainless Steel Trim ³
14	Inlet Tube	Stainless Steel	Stainless Steel
15	Elbow Fitting	Stainless Steel	Stainless Steel
16	Discharge Tube	Stainless Steel	Stainless Steel
17	Support Bracket	Carbon Steel	Carbon Steel
18	Jam Nut	Stainless Steel	Stainless Steel
19	Seal	Teflon	Teflon
20	Pressure Pickup Tube	Stainless Steel	Stainless Steel
21	Plug, 1/4"NPT	Carbon Steel	Carbon Steel
22	Nameplate, Warning	Stainless Steel	Stainless Steel
23	Gasket	Buna-N Elastomer ²	Buna-N Elastomer ²
24	Plug, Pressed In	Stainless Steel	Stainless Steel

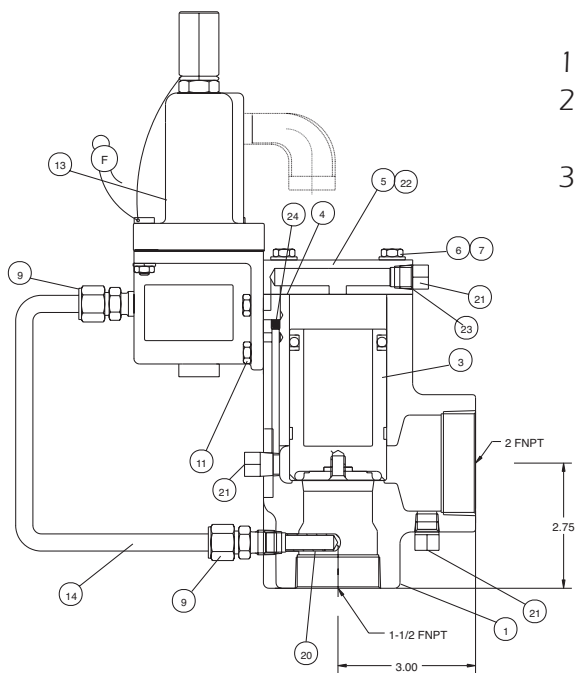

1. Size 1-1/2 x 2: Aluminum
2. Buna-N Standard: Viton, EPR, or other elastomers available upon request
3. All Stainless Steel F100 Pilot Valve available as option

TYPICAL CONFIGURATION

F70PR HIGH PRESSURE

ASSEMBLY

(SIZE 1-1/2 x 2)



CONSTRUCTION

F70PR LOW PRESSURE ASSEMBLY

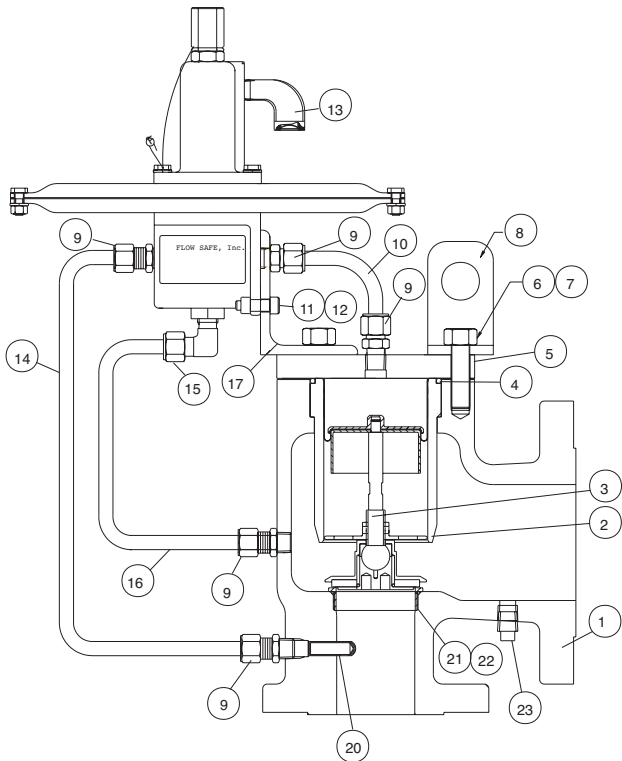

F70PR LOW PRESSURE ASSEMBLY
(SIZES 2x3 & 3x4)

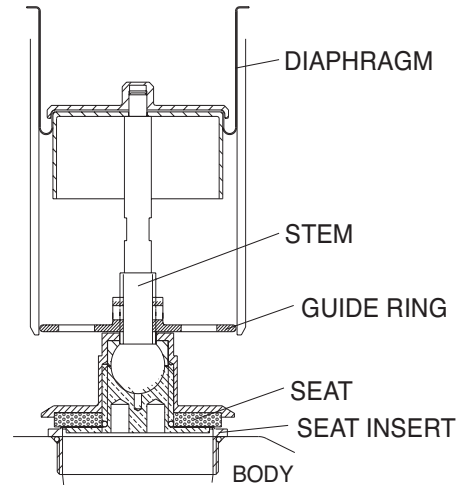

LOW PRESSURE PISTON ASSEMBLY
(SIZES 1-1/2x2, 2x3, & 3x4) □

PRESSURE RANGE
<ul style="list-style-type: none"> • 10"W.C.-5 psig, with F100 Low Pressure Pilot Valve Full Lift within 10% above Set Pressure

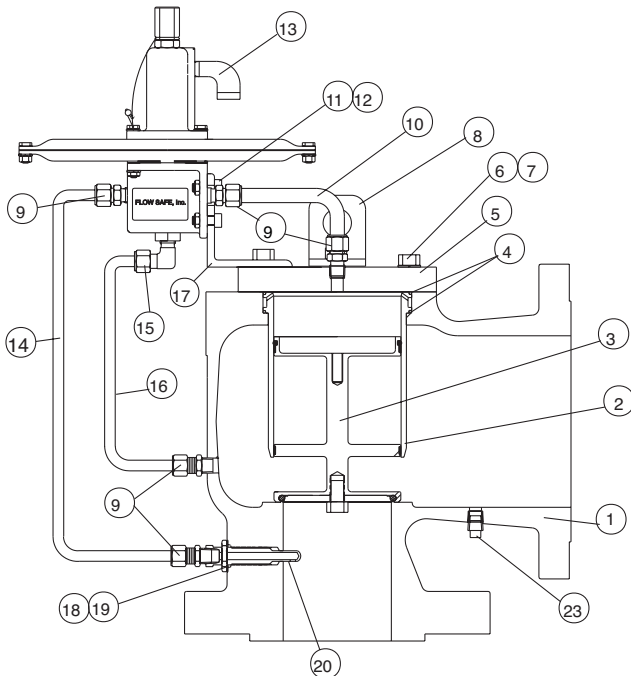

F70PR LOW PRESSURE ASSEMBLY
(SIZES 4x6 & 6x8)

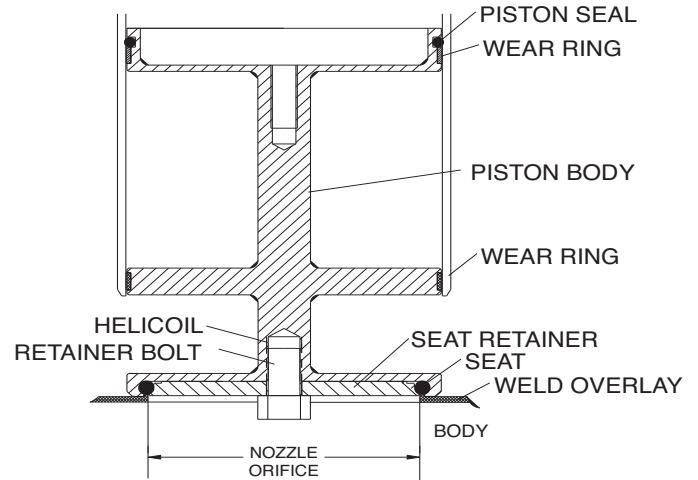

LOW PRESSURE PISTON ASSEMBLY
(SIZES 4x6 & 6x8)

Note: Sizes 8 x 10 and 12 x 16 □
rated to 2 psig minimum

PRESSURE RANGE
<ul style="list-style-type: none"> • 10"W.C.-2 psig, with F100 Low Pressure Pilot Valve (For 2-5 psig, use High Pressure Piston with F100 Low Pressure Pilot Valve) Full Lift within 10% above Set Pressure

CONSTRUCTION

F70PR LOW PRESSURE ASSEMBLY

Item	Description	Materials of Construction
		Standard
1	Body	Carbon Steel (A-216 Gr WCB) ¹
2	Liner	Carbon Steel/Plated ¹
3	Piston Assembly (Low Pressure)	Aluminum (6061) ²
4	Seal	Buna-N Elastomer ³
5	Cap	Carbon Steel ¹
6	Cap Bolt	Carbon Steel/Plated
7	Washer	Carbon Steel/Plated
8	Lift Bracket	Carbon Steel
9	Straight Fitting	Stainless Steel
10	Dome Tube	Stainless Steel
11	Bolt, Mounting	Stainless Steel
12	Nut	Stainless Steel
13	F100 Low Pressure Pilot Valve	Aluminum/Stainless Steel Trim ⁴
14	Inlet Tube	Stainless Steel
15	Elbow Fitting	Stainless Steel
16	Discharge Tube	Stainless Steel
17	Support Bracket	Carbon Steel
18	Jam Nut	Stainless Steel
19	Seal	Buna-N Elastomer ³
20	Pressure Pickup Tube	Stainless Steel
21	Seat Insert	Stainless Steel
22	Seal	Buna-N Elastomer ⁴
23	Plug, 1/4"NPT	Carbon Steel
24	Nameplate, Warning	Stainless Steel

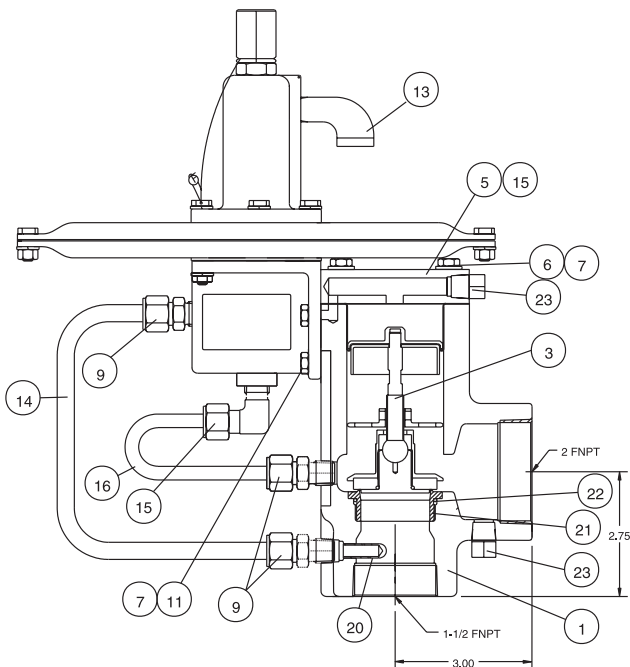

1. Size 1-1/2 x 2: Aluminum
2. Low Pressure Piston available only in aluminum, with Neoprene seat
3. Buna-N Standard: Viton, EPR, or other elastomers available upon request
4. All Stainless Steel F100 Pilot Valve available as option (see pg.10)

TYPICAL CONFIGURATION

F70PR LOW PRESSURE
ASSEMBLY
(SIZE 1-1/2 x 2)



CONSTRUCTION

F100 PILOT VALVES

Item No.	DESCRIPTION	MATERIALS OF CONSTRUCTION	
		STANDARD/ STAINLESS TRIM	STAINLESS STEEL
1	PILOT VALVE BODY	Aluminum (356T6)	Stainless Steel (CF8M)
2	PILOT VALVE BONNET	Aluminum (356T6)	Stainless Steel (CF8M)
3	OUTER SPACER	Aluminum	Stainless Steel
4	INNER SPACER	Aluminum	Stainless Steel
5	SPINDLE	Stainless Steel	Stainless Steel
6	BUSHING	Stainless Steel	Stainless Steel
7	RETAINER	Stainless Steel	Stainless Steel
8	DIAPHRAGM		
9	JAM NUT	Stainless Steel	Stainless Steel
10	SPRING WASHER	Stainless Steel	Stainless Steel
11	DIAPHRAGM	Teflon/Buna-N ¹	Teflon/Buna-N ¹
12	BOLT	Stainless Steel	Stainless Steel
13	PRESSURE ADJUSTMENT SCREW	Stainless Steel	Stainless Steel
14	LOCKING NUT	Stainless Steel	Stainless Steel
15	CAP	Stainless Steel	Stainless Steel
16	LOCKING WIRE	Stainless Steel	Stainless Steel
17	LOCKWIRE SEAL	Lead	Lead
18	NAMEPLATE/ DRIVE PINS	Stainless Steel	Stainless Steel
19	SPRING	Carbon Steel/ Plated	Stainless Steel
20	SEAT	Buna-N ²	Buna-N ²
21	NUT	Stainless Steel	Stainless Steel
22	LOCKWASHER	Stainless Steel	Stainless Steel
23	RETAINER SCREW	Stainless Steel	Stainless Steel
24	BUG SCREEN	Stainless Steel	Stainless Steel
25	GASKET	Buna-N ²	Buna-N ²
26	INLINE SCREEN (100 Micron)	Stainless Steel	Stainless Steel
27	SEAL	Buna-N ²	Buna-N ²
28	SEAL	Buna-N ²	Buna-N ²
29	GASKET	Buna-N ²	Buna-N ²
30	INSERT	Stainless Steel	Stainless Steel
31	UPPER HOUSING, LOW PRESSURE	Stainless Steel	Stainless Steel
32	LOWER HOUSING, LOW PRESSURE	Stainless Steel	Stainless Steel
33	BOLT	Stainless Steel	Stainless Steel
34	SCREW	Stainless Steel	Stainless Steel
35	SEAL	Buna-N ²	Buna-N ²
35	SEAL	Buna-N ²	Buna-N ²

1. Teflon: 10"W.C. - 150 psig
Elastomer: 150 -285 psig
2. Buna-N Standard: Viton, EPR, or other elastomers available upon request

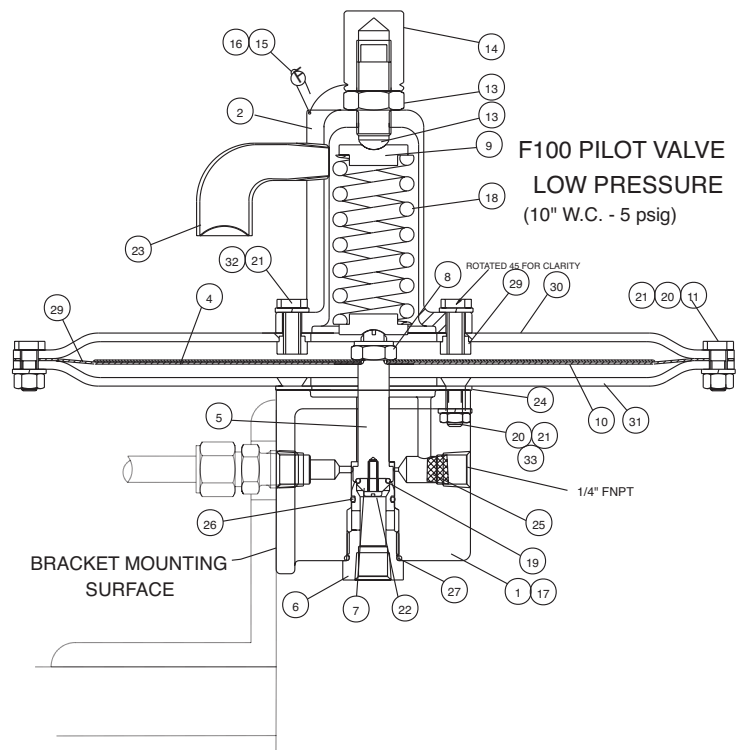
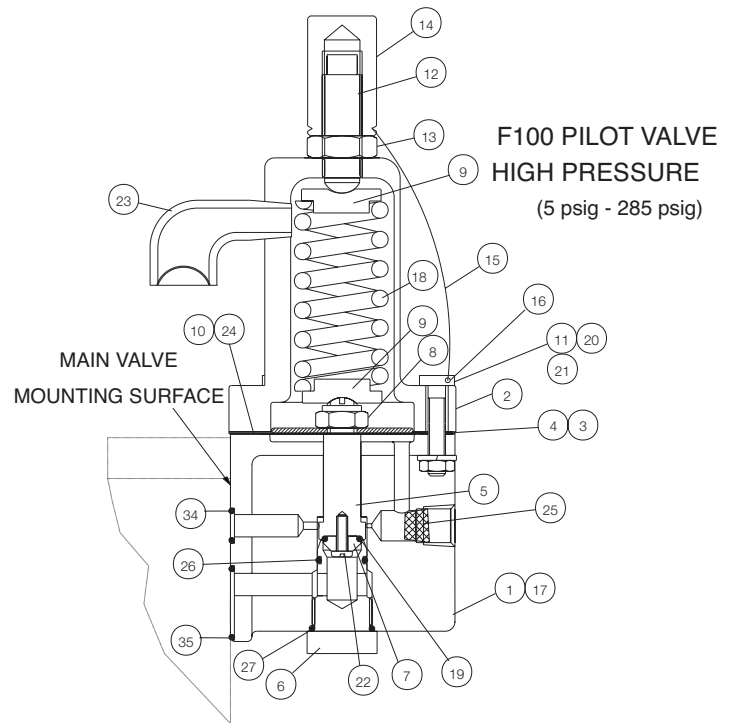

ACCESSORIES AND OPTIONS

F70PR SERIES

Field Test Connection(T) (Part No. 00-4450-01)

This allows the user to verify the set pressure while in service without valve removal. An external pressure source may be attached to the FTC to direct pressure to the pilot valve, while blocking off the inlet pressure, thus checking the set pressure and the general operation of the valve.

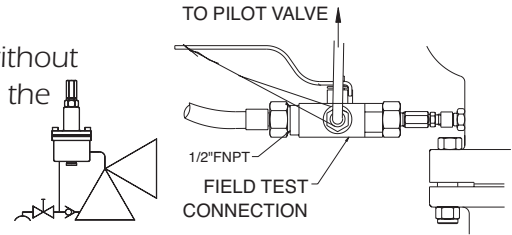

Inlet Supply Filter (F)(Part No. 12-4302)

This should be used for dirty applications to clean the supply gas to the pilot valve. This is supplied with a purge vent.

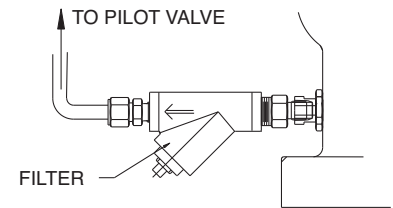
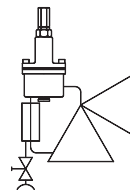

Remote Pressure Pickup(R)

Remote pressure pickup is recommended when inlet piping pressure losses exceed 3% to the relief valve. This allows a remote, more direct pressure sensing to the pilot valve, plus an excellent source of clean air.

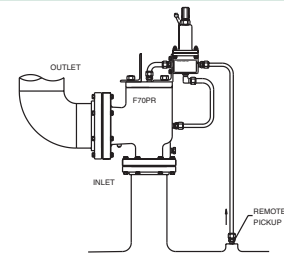
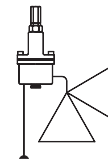

Manual Blowdown(M) (Part No. 00-4600)

Allows for main valve lift by bypassing the pilot valve. Accomplished by a manual blowdown valve.

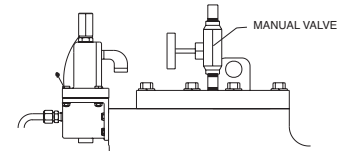
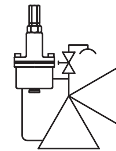

Remote-Unload Blowdown(SC or SO)

Allows for main valve lift by bypassing the pilot valve. Ideal as an unloading valve to eliminate/vent system pressure for positive displacement blowers, or to act as an Emergency Shutdown Device(ESD)for the natural gas compressor industry.

Accomplished by use of an automatic blowdown valve, pneumatic, hydraulic, or electric valve. Automatic valves can be provided in AC or DC, Normally Closed or Normally Open(preferred as fail safe)

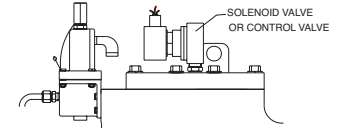
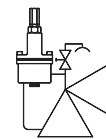

Backflow Preventer(P) (Part No. 00-4501-03)

To prevent backflow into the system, when outlet pressure exceeds the inlet pressure, a backflow preventer can be provided. The outlet pressure is routed to the main valve dome, to ensure that the piston remains closed.

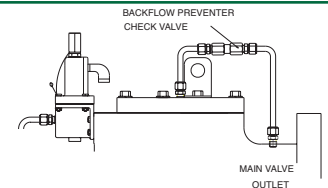
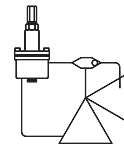

Closed Dome Tee(D) (Part No. 00-6001)

This allows the user to verify the set pressure while in service without valve removal. A tee is provided on the main valve cap to attach a gage or any other instrumentation.

Diverter Assembly(V) (Part No. 52-100X)

Two F70PR's can be supplied with a diverter valve to allow switching for maintenance and servicing.

Dual Pilot Valves(Y)

Two F100 Pilot Valves can be supplied mounted to the F70 main valve assembly, with a switchover valve in between. The Pilot valves can be set at two separate set pressures, allowing the operator the flexibility to change the set point or perform maintenance on one of the pilot valves.

Listed below are the equations to calculate the flow capacities of the F70PR Pressure Relief Valves.

SUBCRITICAL(SUBSONIC) FLOW: Low Pressure Flow, where set pressures are P_{cf} or less, or for set pressures above P_{cf} where flow becomes subsonic due to subcritical pressure drop across the valve(due to backpressure). For the F70PR, Equation 1 is used up to pressures where the sonic flow coefficient K_d is constant.

$$\textcircled{1} \quad V_{ss} = [4645 \times P_1 \times (K_d \times A_o) \times F] \left[\frac{1}{M \times T \times Z} \right]^{1/2}$$

(See Figure 1 below)

Inversely, to determine the required orifice Area(A_o):

$$\textcircled{1a} \quad A_o = \frac{V_{ss} (M \times T \times Z)^{1/2}}{4645 \times P_1 \times F \times K_d}$$

$$\textcircled{2} \quad F = \sqrt{\left[\frac{k}{k-1} \right] [(r)^{2/k} - (r)^{(k+1)/k}]}$$

$$\textcircled{3} \quad r = P_2 / P_1$$

A_o =Orifice Area(sq. inches)
 $k=c_p/c_v$ =specific heat ratio of the gas
 K_d =Verified Flow Coefficient
 (No Derating Factor used, as F70PR does not bear ASME UV stamp)
 M =Molecular Weight
 $P_1 = 1.1 \times P + 14.7$ (psia)
 P = Set pressure(psig)
 P_2 =Pressure at exhaust of valve(psia)
 T =Flowing Temperature($^{\circ}R = ^{\circ}F + 460$)
 V_{ss} =Subsonic Flow Rate(SCFM)
 Z =Compressibility Factor(Use=1, if unknown)

CRITICAL(SONIC) FLOW : High Pressure Flow, where set pressures are greater than P_{cf} . If backpressure causes P_2/P_1 to be greater than the critical ratio(Eq. 4), then use Equation 1. This flow condition may also be termed "Choked" flow. Flow is critical when:

$$\textcircled{4} \quad \frac{P_{cf}}{P+14.7} \leq \left[\frac{2}{k+1} \right]^{k/(k-1)}$$

V_s =Sonic Flow Rate(SCFM)
 C = Gas Coefficient based upon k
 (If unknown, use $C=315$)

$$\textcircled{5} \quad V_s = \frac{6.32 \times C \times P_1 \times (K_d \times A_o)}{(M \times T \times Z)^{1/2}}$$

Inversely, to determine the required orifice Area(A_o) for a given Flow rate(V):

$$\textcircled{5a} \quad A_o = \frac{V \times (M \times T \times Z)^{1/2}}{6.32 \times C \times P_1 \times K_d}$$

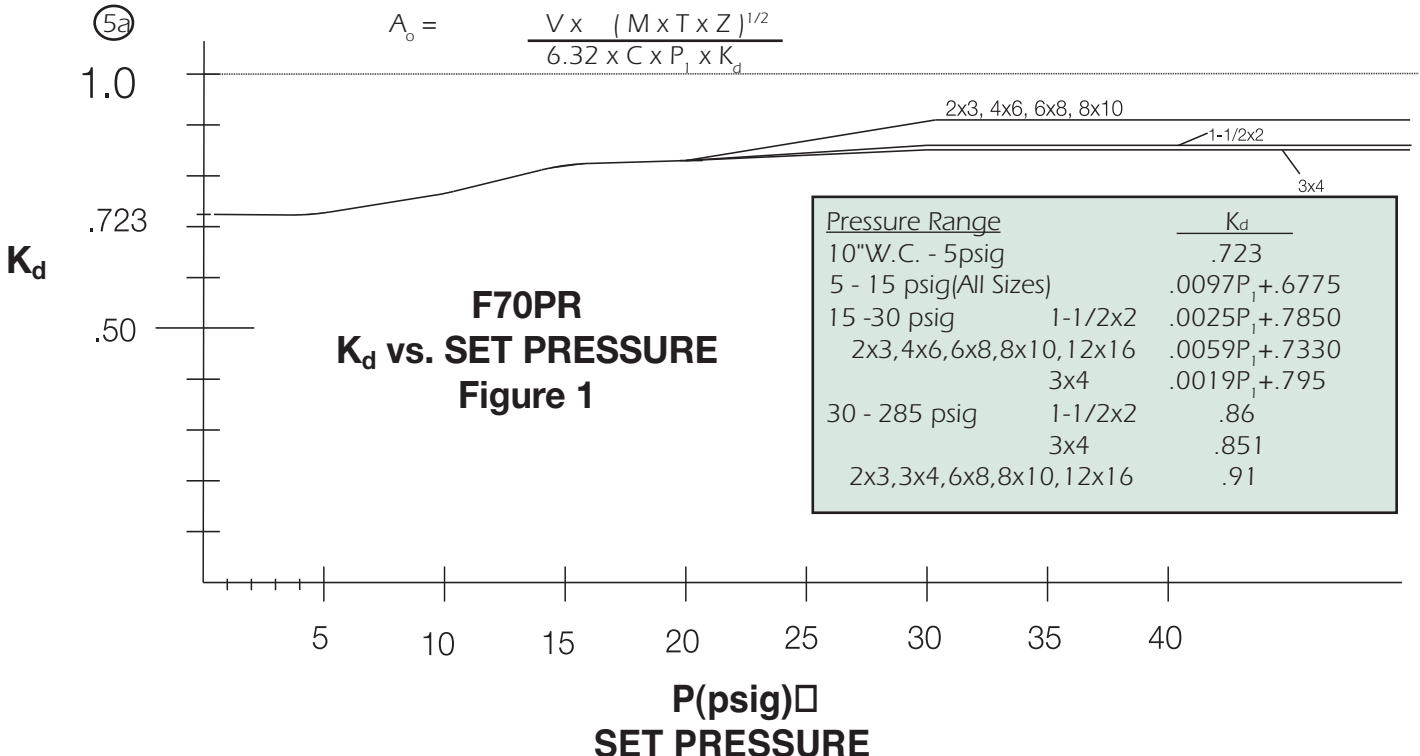

FLOW CAPACITIES (SCFH AT 60°F AT 10% OP)

F70PR SERIES

SET PRESSURE	TYPE PILOT ²	SIZE(inches)							
		(NOZZLE AREA(in ²))							
		AIR(MW=29)							
		(LB/HR=.076 x SCFH)							
		1-1/2x2	2x3	3x4	4x6	6x8	8x10	12x16	
		(1.77)	(3.32)	(7.33)	(11.43)	(26.06)	(45.64)	(111.87)	
		K _d ¹	.86	.91	.851	.91	.91	.91	
10" WC	LP		7250	13807	30370	46923	106908	187249	458974
15" WC	LP		8615	16406	34774	55756	127033	222498	545374
20" WC	LP		9834	18727	41192	63643	145003	253973	622524
25" WC	LP		10989	20298	46032	71121	162040	283814	695667
1 psig	LP		11629	22146	48711	75260	171471	300332	736155
5 psig	HP		25799	49132	108069	166971	380425	666314	1633229
10 psig	HP		38214	72775	160074	247321	563494	986959	2419174
15 psig	HP		49504	94276	207365	320387	729967	1278536	3133870
25 psig	HP		63945	121777	267857	413849	942911	1651506	4048073
50 psig	HP		116445	234652	482667	797443	1816886	3182273	7800195
80 psig	HP		171577	345749	711189	1174998	2677105	4688945	11493257
100 psig	HP		208332	419814	863538	1426702	3250584	5693393	13955299
125 psig	HP		254275	512395	1053973	1741331	3967433	6948952	17032851
137 psig	HP		276328	556835	1145382	1892353	4311520	7551621	18510076
160 psig	HP		318596	642009	1320583	2181812	4971021	8706736	21341423
180 psig	HP		355351	716074	1472931	2433516	5544500	9711184	23803465
200 psig	HP		392105	790139	1625279	2685219	6117979	10715632	26265506
220 psig	HP		428860	864204	1777627	2936923	6691458	11720079	28727548
240 psig	HP		465614	938270	1929976	3188626	7264937	12724527	31189589
260 psig	HP		502365	1012335	2082324	3440330	7838417	13728975	33651631
285 psig	HP		548312	1104916	2272759	3754959	8555265	14984535	36729183

1. K_d = Flow Coefficient, Critical Flow. See Page 12 for subcritical K_d values

2. LP - LOW PRESSURE HP-HIGH PRESSURE

		NATURAL GAS(MW=19)							
		(LB/HR=.05 x SCFH)							
		1-1/2x2	2x3	3x4	4x6	6x8	8x10	12x16	
		(1.77)	(3.32)	(7.33)	(11.43)	(26.06)	(45.64)	(111.87)	
		K _d ¹	.86	.91	.851	.91	.91	.91	
10" WC	LP		8949	17043	37487	57919	131961	231130	566531
15" WC	LP		10762	20495	45079	69650	158689	277944	681279
20" WC	LP		12122	23086	50779	78455	178752	313083	767411
25" WC	LP		13538	25782	56709	87818	199627	349647	857032
1 psig	LP		14321	27273	59988	92685	211172	369867	906595
5 psig	HP		31382	58764	131455	203104	462750	810506	1986664
10 psig	HP		45921	87451	192355	297196	677128	1185988	2907022
15 psig	HP		58902	112173	246732	381211	868548	1521261	3728823
25 psig	HP		74916	142669	313809	484848	1104674	1934835	4742551
50 psig	HP		139416	280941	577882	954752	2175299	3810033	9338922
80 psig	HP		205424	413954	851484	1406787	3205211	5613923	13760507
100 psig	HP		249429	502630	1033886	1708144	3891819	6816516	16708230
125 psig	HP		304436	613475	1261888	2084839	4750079	8319757	20392883
137 psig	HP		330839	666680	1371329	2265653	5162044	9041313	22161517
160 psig	HP		381445	768657	1581091	2612213	5951643	10424295	25551398
180 psig	HP		425450	857333	1763493	2913570	6638251	11626887	28499121
200 psig	HP		469455	946008	1945894	3214927	7324859	12829480	31446844
220 psig	HP		513460	1034684	2128296	3516283	8011468	14032073	34394567
240 psig	HP		557465	1123360	2310698	3817640	8698076	15234666	37342290
260 psig	HP		601470	1212036	2493099	4118996	9384684	16437259	40290013
285 psig	HP		656477	1322880	2721101	4495692	10242944	17940501	43974667

■ SUBCRITICAL FLOW

□ CRITICAL FLOW



SPECIFICATIONS

F70PR SERIES

SET PRESSURE RANGE, LOW PRESSURE(LP) ²	10"WC to 5 psig
SET PRESSURE RANGE, HIGH PRESSURE(HP) ²	5 psig to 285 psig (ANSI 150)
PROCESS TEMPERATURE RANGE(Continuous)	-65°F to 275°F (400°F w/VITON)
MAIN VALVE BODY & LINER MATERIAL ¹	CARBON STEEL (ALUMINUM-1-1/2x2) or STAINLESS STEEL
MAIN VALVE TRIM MATERIAL	ALUMINUM
PILOT VALVE BODY MATERIAL ¹	ALUMINUM
PILOT VALVE TRIM MATERIAL	STAINLESS STEEL
SEAT & SEAL MATERIAL ¹	BUNA-N ELASTOMER (VITON or OTHER UPON REQUEST)
FITTING MATERIAL	STAINLESS STEEL

1. OTHER MATERIALS CAN BE PROVIDED UPON REQUEST

2. FULL LIFT WITHIN 10% ABOVE SET PRESSURE

SEAT DATA

Seat Material	Continuous Process Temperature(°F)		Pressure Range(psig)	
	Min	Max	Min	Max
Buna-N	-65	275	5	285
Viton®	-65	400	5	285
Ethylene Propylene(EPR)	-65	325	5	285
Kalrez®	0	500	5	285
Neoprene(Low Pressure)	-20	200	10"W.C.	5

Note: Viton, Kalrez are registered trademarks of the E.I.DuPont De Mours Company

DIMENSIONS & WEIGHTS

SIZE	WEIGHT (lbs)	CONNECTIONS		MAXIMUM DIMENSIONS(inches)					
		INLET	OUTLET	A	B	C	D	E	F
1-1/2x2	15	1-1/2"FNPT	2"FNPT	2.75	3.00	13.50	13.50	14.50	13.50
2x3	60	2"150#RF	3"150#RF	4.56	5.30	17.50	16.00	18.50	16.00
3x4	85	3"150#RF	4"150#RF	5.70	7.00	20.50	17.50	21.50	17.50
4x6	170	4"150#RF	6"150#RF	7.75	8.25	18.50	19.00	19.50	19.00
6x8	300	6"150#RF	8"150#RF	9.44	9.50	22.50	22.00	23.50	22.00
8x10	500	8"150#RF	10"150#RF	10.88	11.00	30.25	24.50	31.25	24.50
12x16	1200	12"150#RF	16"150#RF	11.95	15.62	32.95	32.65	37.75	33.30

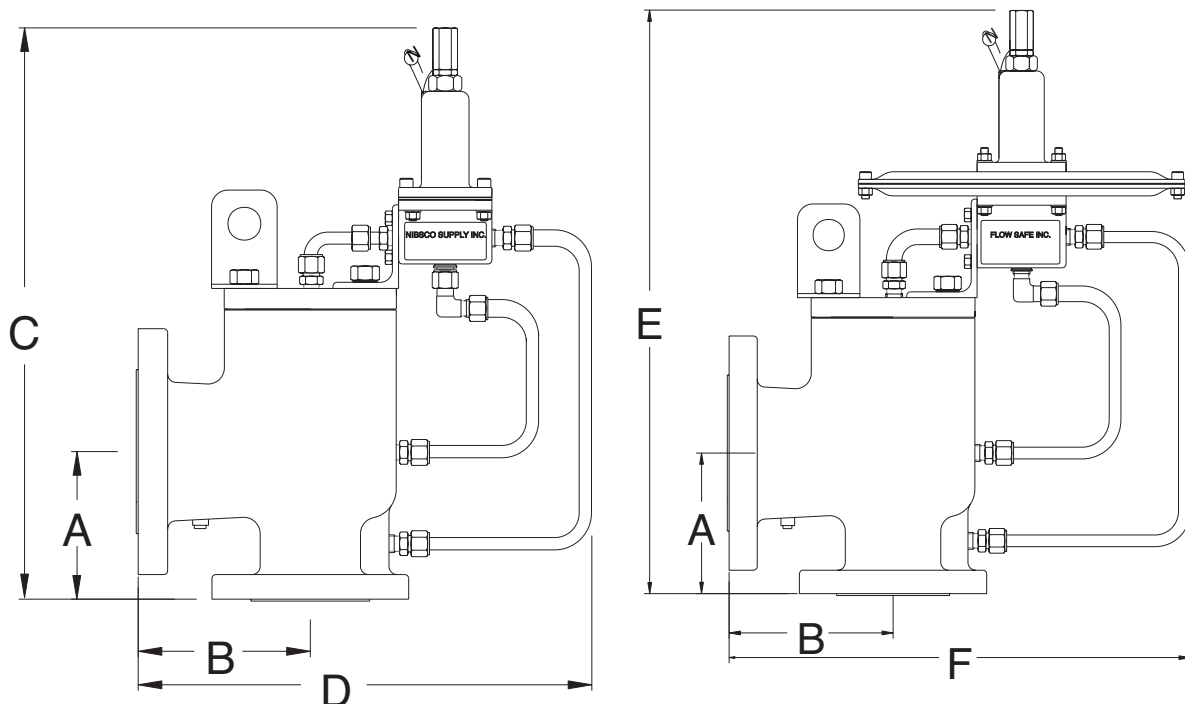

HOW TO ORDER

F70PR SERIES

To properly order and process a F70PR, please specify the following:

1. Quantity required; Required Ship date(s), agreed to on quotation.
2. Inlet size and flange rating
3. Outlet size and flange rating
4. FLOW SAFE Part Number. See below.
5. Material Requirements: Main Valve, Main Valve Trim, Pilot Valve, Softgoods
6. Operating Conditions. See Specifications form.
7. Optional Accessories. See page 11
8. Any Special Requirements
9. Required Documentation
10. Valve Tagging Requirements
11. Any special packaging instructions
12. Shipping instructions

PART NUMBERING

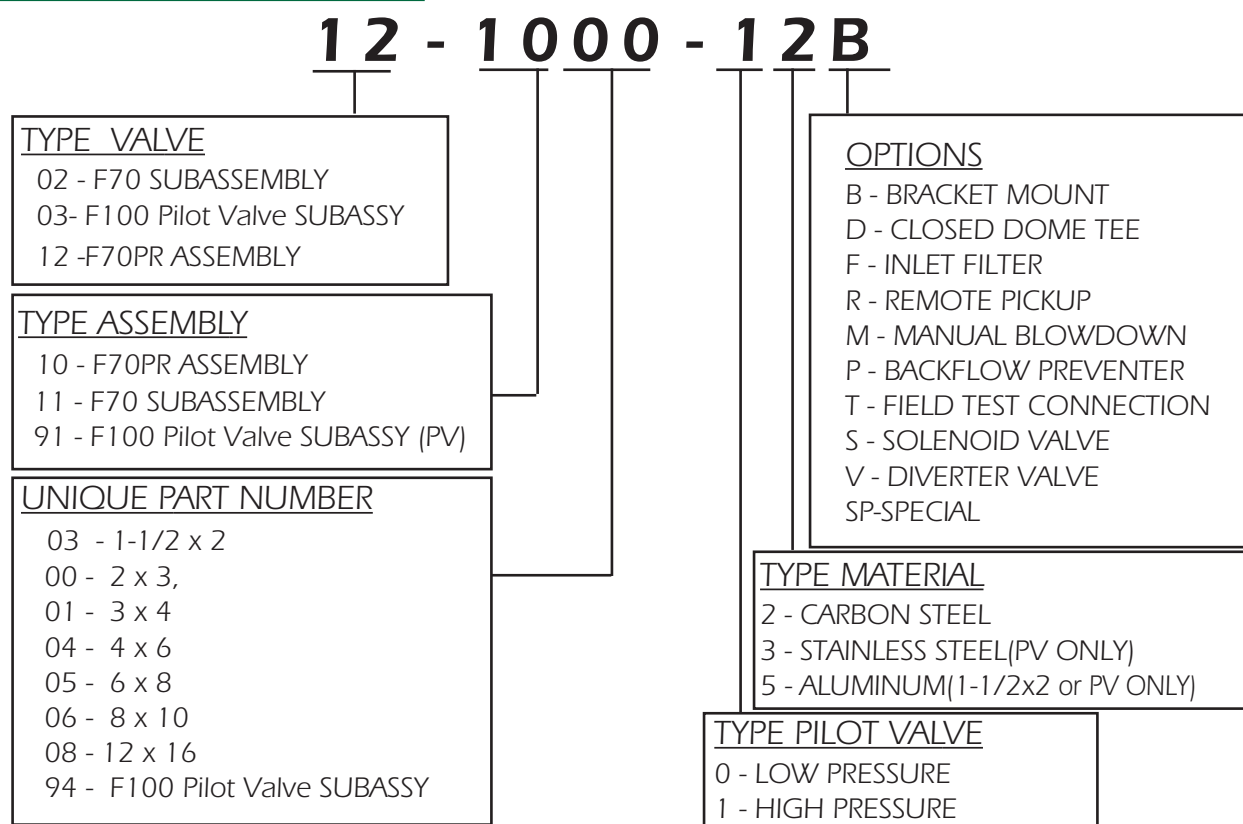

EXAMPLES:

1. Conditions: Operating Pressure=42 psig, Set Pressure = 50 psig,
Media:Natural Gas, Capacity Required = 500000 SCFH,
Accessories: Filter
Order: P/N 12-1001-12BF, F70PR HP, 3x4, Set Pressure = 50 psig
2. Conditions: Operating Pressure=8" WC, Set Pressure = 10" WC,
Media:Natural Gas, Capacity Required = 45000 SCFH,
Accessories: Field Test Connection & Filter
Order: P/N 12-1004-02BFT, F70PR LP, 4x6, Set Pressure = 10"WC
3. Conditions: Operating Pressure=160 psig, Set Pressure = 180 psig,
Media:Natural Gas, Capacity Required = 800000 SCFH,
Accessories: Field Test Connection
Order: P/N 12-1006-12T, F70PR HP, 8x10, Set Pressure = 180 psig





FLOW SAFE, Inc.

"Environmental Performance for Industry"

High Performance Relief Valve Products

F80 Series



F84/85 Series
Safety Relief Valve

F70 Series



F70U Series
Unloader Valve

F7000/8000 Series



F7000/8000 Series
Safety Relief Valve



F80M Series with Whistle
(This is not a relief device as shown)



F70PR Series
Pressure Relief Valve



F7000/8000 Series
Safety Relief Valve - IM Construction



F84L Series
Liquid Relief Valve

The policy of Flow Safe and its authorized assemblers is a commitment to value through:

- Environmentally Compatible Products
- Cost Efficient Designs, with Minimal Parts
- Quality Products, Readily Available
- Flexibility, to meet unique customer needs
- Products built in accordance with the requirements of ASME Boiler & Pressure Vessel Code, Section VIII
- "No Hassle" Service

For more information, visit our website www.flowsafe.com

"Advanced Technology for the NEW MILLENNIUM"

S-3865 Taylor Road • Orchard Park, New York 14127 • 716-667-3641 • 716-667-3642 (Fax)