



Model **DFC AND DFO** Valve Actuator

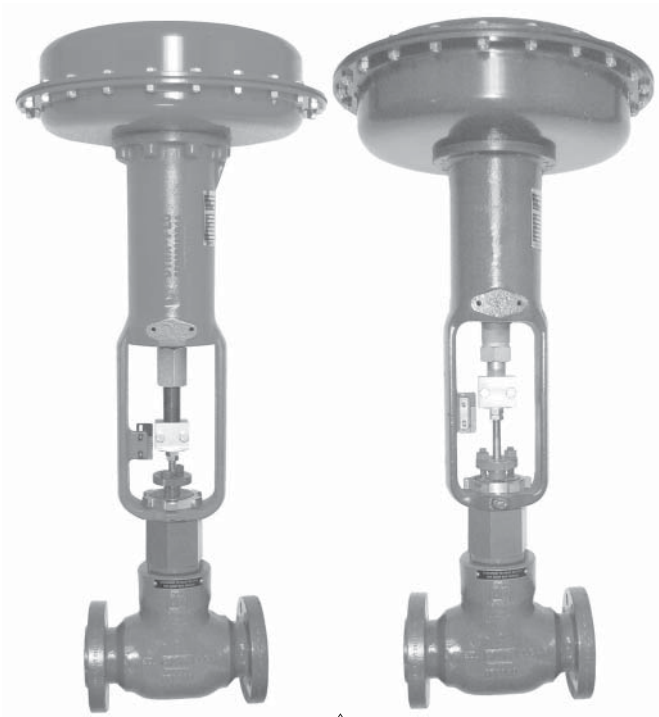

Figure 1 Models DFC and DFO Actuators

The Model DFC and DFO series linear output spring and diaphragm actuators are used in all kinds of demanding applications. The large area of the diaphragm allows low-pressure operation, and the spring provides fail safe positioning of a control valve on loss of the pneumatic supply. Both model DFC and DFO are used to automate control valves in both throttling and on/off control of liquids or gases.

When combined with a Dyna-Flo Model DF2000 or 360 valve, the DFC or DFO is part of a rugged control valve assembly, to which a wide variety of controllers and instruments can be attached.

Dyna-Flo's high level of quality specifications used in manufacturing the Model DFC and DFO series linear pneumatic actuators ensures superior performance and customer satisfaction.

Features

Reliable Design

Formed diaphragm has no friction with other moving parts allowing maintenance free operation through years of constant cycling.

Protective Coatings

External surfaces are either epoxy or powder coated for optimum resistance to harsh environments.

Individually Tested

Each actuator receives extensive testing to confirm smooth leak free operation.

Designed for Instrument Mounting

Integrated mounting pads with threaded holes make easy work of mounting instruments to the actuator. The open yoke allows easy access to stems for feed arms.

Travel Indication

Highly visible travel scale is adjustable for precise position indication.



Model DFC AND DFO Valve Actuator

Specifications

Material Temperature Capabilities

Standard: -40 to 180 °F (-40 to 82 °C)

Construction Materials

See Table 3 for construction details.

Contact your Dyna-Flo sales office for more information and other options.

Valve Stem Compatibility, inches (mm)

1069	3/8 (9.5)
2069, 2105, 2156	1/2 (12.7)
3105, 3156, 3220	3/4 (19)

Valve Mounting Connection Sizes, inches (mm)

1069	2-1/8 (54)
2069, 2105, 2156	2-13/16 (71)
3105, 3156, 3220	3-9/16 (90)

Actuator Weights, lb (kg)

	DFC	DFO
1069	48 (22)	40 (22)
2069	50 (23)	51 (23)
2105	90 (41)	82 (37)
2156	121 (55)	107 (49)
3105	94 (43)	92 (42)
3156	122 (55)	116 (53)
3220	254 (115)	235 (107)

Line Connection Size

All sizes, 1/4 inch FNPT, other sizes available

Actuator Mounting

Vertical on valve yoke

360° rotatable for optimum accessory orientation

Actuator Dimensions

See Figure 2 for actuator diagram

See Table 2 for actuator dimensions

Options

Reduced travel output

Increased tubing connection size

Stem connections

Mechanical Travel stops

Corrosion resistant materials

For more information and other options contact your Dyna-Flo sales office.

Operation

The Model DFC spring return diaphragm actuator (Fig. 3) employs time proven reliable technology. As the instrument signal to the sealed lower actuator casing (Key 3) is increased, the force generated by that pressure on the diaphragm (Key 12), and diaphragm plate (Key 10), force the diaphragm plate and actuator stem (Key 20) up, compressing the spring (Key 2). The lifting action is transferred to the valve stem through a secure split and bolted stem connector (Key 23). On a decrease, or complete loss of pneumatic signal, the actuator spring (Key 2) will force the actuator stem (Key 20) to extend, putting the valve in it's failsafe position.

Using a push down to close action valve with a Model DFC will result in a fail closed valve assembly.

The Model DFO spring return diaphragm actuator is also time proven. Refer to Figure 4. As the instrument signal to the sealed upper actuator casing (Key 1) is increased, the force generated by that pressure on the diaphragm (Key 2), and diaphragm plate (Key 3), force the diaphragm plate and actuator stem (Key 8) down, compressing the spring (Key 10). The extension action is transferred to the valve stem through a secure split and bolted stem connector (Key 13). On a decrease, or complete loss of pneumatic signal, the actuator spring (Key 10) will force the actuator stem (Key 8) to retract, putting the valve in it's failsafe position.

Using a push down to close action valve with a Model DFO will result in a fail open valve assembly.

Handwheels

There are two types of manual override available for the DFC and DFO. The simple, cost effective option is the top mounted handwheel, and the more convenient option is the side-mounted handwheel.

The top mounted handwheel is a good choice for emergency only positioning of a valve, and it is commonly used as a travel stop. It is available for all sizes of DFC and DFO.

The side-mounted handwheel is the right selection for an application that requires frequent manual positioning. The flexibility of the side-mounted handwheel allows it to limit operation in either direction, but only one direction at a time. It is available for sizes 1069 and larger.

External Travel Stops

Top mounted handwheel based travel stops are available to restrict valve opening or closing. Configurations are available with caps to reduce tampering.



Model DFC AND DFO Valve Actuator

Table 1

Maximum Travel, Thrust and Casing Pressure for a given diaphragm area

Actuator Size	Active Diaphragm Area in ² (cm ²)	Thrust Limit lb (N)	Travel Maximum in (mm)	Maximum Casing Pressure			
				DFC		DFO	
				Maximum Pressure for Sizing psig (kPag)	Safety psig (kPag)	Maximum Pressure for Sizing psig (kPag)	Safety psig (kPag)
1069	69 (445)	2300 (10,200)	0.75 (19)	70 (480)	90 (620)	65 (450)	75 (520)
2069	69 (445)	2700 (12,000)	1.5 (38)	70 (480)	90 (620)	65 (450)	75 (520)
2105	105 (677)	5600 (25,100)	2.0 (51)	65 (450)	75 (520)	50 (340)	60 (410)
2156	156 (1006)	7500 (33,500)	2.0 (51)	55 (350)	65 (450)	40 (280)	50 (340)
3105	105 (677)	5600 (25,100)	2.0 (51)	65 (450)	75 (520)	50 (340)	60 (410)
3156	156 (1006)	6800 (30,200)	2.0 (51)	55 (350)	65 (450)	40 (280)	50 (340)
3220	220 (1420)	8800 (39,100)	4.0 (102)	50 (340)	60 (410)	55 (350)	65 (450)

Figure 2 Model DFC and DFO Outline Dimension Drawing

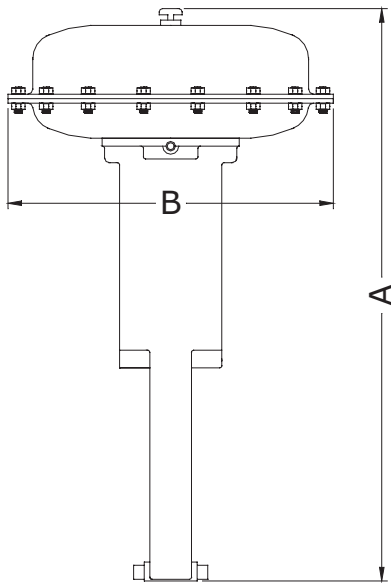

Table 2

Model DFC and DFO Outline Dimensions in. (mm)

Actuator Size	Dimension Reference		
	Inch (mm)		Inch (mm)
	A	B	
	DFC	DFO	
1069	22.6 (574)	19.6 (498)	13.12 (333)
2069	23.4 (594)	21.6 (549)	13.12 (333)
2105	30.3 (770)	25.9 (658)	16.00 (406)
2156	29.4 (747)	25.8 (655)	18.62 (473)
3105	30.9 (785)	28.4 (721)	16.00 (406)
3156	30.9 (785)	28.4 (721)	18.62 (473)
3220	36.8 (935)	33.1 (841)	21.10 (536)



Model DFC AND DFO Valve Actuator

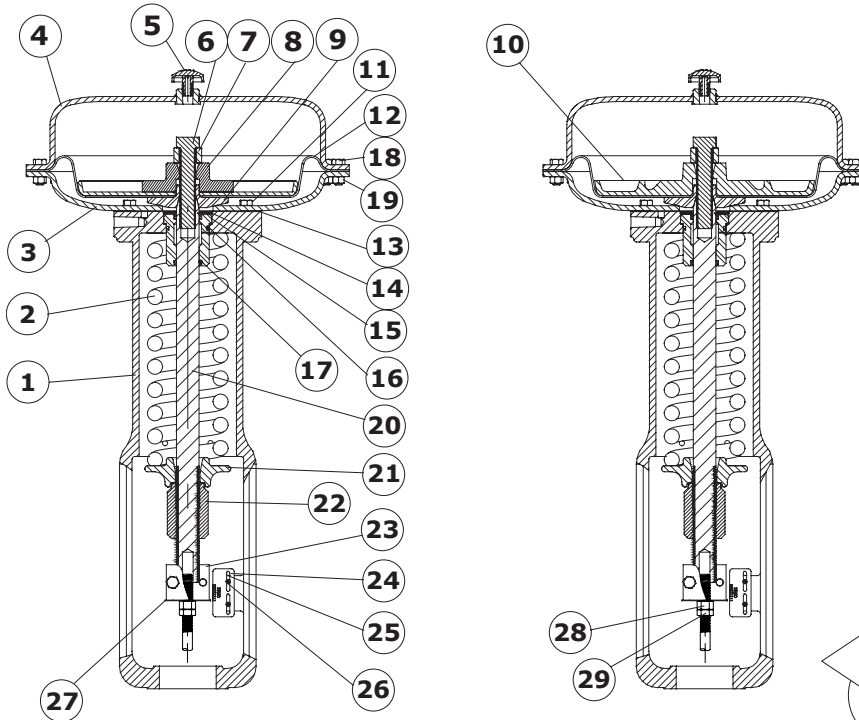

Figure 3 DFC Actuator
Typical Cross Section

Table 3

Model DFC Standard Construction Materials

Key	Description	Material	Key	Description	Material
1	Yoke	Cast Iron	15	Bushing	Brass
2	Spring	Steel	16	O-Ring	Buna
3	Lower Casing	Steel	17	O-Ring	Buna
4	Upper Casing	Steel	18	Hex Head Bolt	ST. ZI. PL.
5	Vent	Plastic	19	Nut	ST. ZI. PL.
6	Hex Head Bolt	ST. ZI. PL.	20	Stem	17-4
7	Travel Stop	Steel	21	Spring Seat	Steel PL.
8	Diaphragm Plate Ass'y*	ST. ZI. PL.	22	Spring Adjuster	Steel PL.
9	Lwr Diaphragm Plate	Steel	23	Stem Connector Assembly	Steel PL.
10	Diaphragm Plate*	Cast Iron	24	Travel Scale	SST
11	Hex Head Bolt	ST. ZI. PL.	25	Speed Nut	SST
12	Diaphragm	Nitrile / Nylon	26	Screw	SST
13	Gasket	Comp.	27	Travel Disc	SST
14	Snap Ring	SST	28, 29	Stem Nut , Jam Nut	Steel-Plated

* DFC actuators have either a diaphragm plate assembly (Key 8) or a diaphragm plate (Key 10) depending on date of manufacture and model. See instruction manual for details.



Model DFC AND DFO Valve Actuator

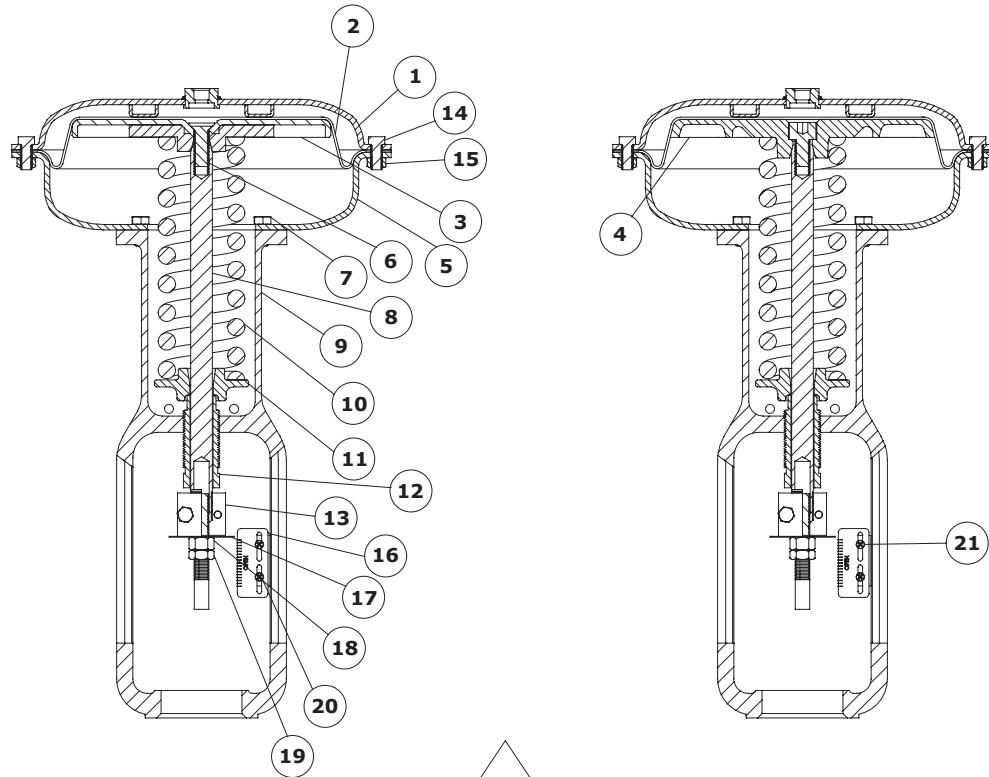

Figure 4 DFO Actuator Typical Cross Section

Table 4

Model DFO Construction Materials

Key	Description	Material	Key	Description	Material
1	Upper Casing	Steel	12	Spring Adjuster	Steel-Plated
2	Diaphragm	Nitrile / Nylon	13	Stem Connector Ass'y	Steel-Plated
3	Diaphragm Plate Ass'y*	Steel	14	Hex Head Bolt	Steel-Plated
4	Diaphragm Plate*	Cast Iron	15	Nut	Steel-Plated
5	Lower Casing	Steel	16	Travel Scale	SST
6	Socket Cap Screw	Steel	17	Travel Disc	SST
7	Hex Head Bolt	Steel-Plated	18	Stem Nut	Steel-Plated
8	Stem	17-4	19	Jam Nut	Steel-Plated
9	Yoke	Cast Iron	20	Machine Screw	Steel-Plated
10	Spring	Steel	21	Speed Nut	SST
11	Lower Spring Seat	Steel-Plated			

* DFO actuators have either a diaphragm plate assembly (Key 3) or a diaphragm plate (Key 4) depending on date of manufacture and model. See instruction manual for details.



Model DFC AND DFO Valve Actuator

Table 5

Model DFO Actuator Thrust Available by Bench Range (psig / kPag)

Actuator Size	Travel Inches (mm)	Bench Range - psig (kPag)			Bench Range - psig (kPag)		
		3 - 15 (21 - 103)	3 - 11 (21 - 76)	3 - 9 (21 - 62)	6 - 30 (41 - 207)	6 - 26 (41 - 179)	6 - 22 (41 - 152)
		lbf (N)	lbf (N)	lbf (N)	lbf (N)	lbf (N)	lbf (N)
1069^A and 2069	3/4 (19) to 1-1/2 (38)	207 (921)	438 (2148)	621 (2762)	207 (921)	483 (2148)	759 (3376) ^B
2105 and 3105	3/4 (19) to 2 (51)	315 (1401)	630 (2802)	945 (4204)	315 (1401)	735 (3269)	1155 (5138)
2156 and 3156	3/4 (19) to 2 (51)	468 (2082)	1092 (4857)	1404 (6245)	468 (2082)	1092 (4857)	1716 (7633)
3220	3/4 (19) to 1-1/2 (38) to 2 (51)	880 (3914) ^A	1320 (5872) ^D	1980 (8807)	2640 (11743) ^E	3520 (15658) ^F	Consult Dyna-Flo 2640 (11743) ^E

NOTES:

- A - 1-1/8" (29 mm) MAX Travel
- B - Consult Dyna-Flo on 2069 thrust value
- C - 3-14 psig (21 - 97 kPag)
- D - 3-12 psig (21 - 83 kPag)
- E - 6-21 psig (41 - 145 kPag)
- F - 6-17 psig (41 - 117 kPag)
- G - 6-19 psig (41 - 131 kPag)
- H - 2200 lb-f, 6-23 psig (41 - 159 kPag) at 1-1/2" travel

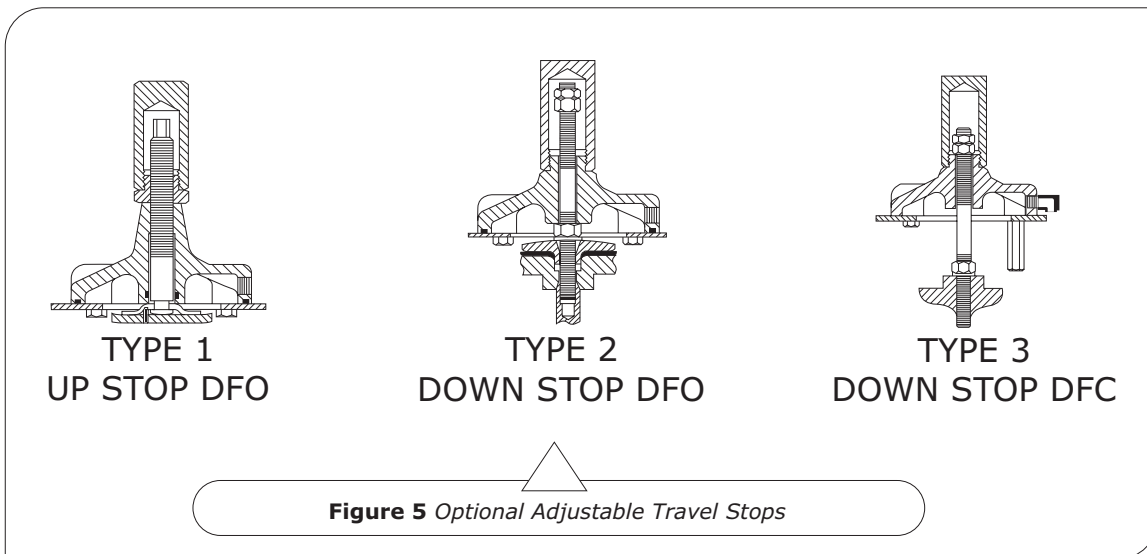



Model DFC AND DFO Valve Actuator

Table 6

Model DFC Actuator Thrust Available by Bench Range (psig / kPag)

Actuator Size	Travel Inches (mm)	Bench Range - psig (kPag)			Bench Range - psig (kPag)		
		3 - 15 (21 - 104)	6 - 15 (41 - 104)	8 - 15 (55 - 104)	6 - 30 (41 - 207)	10 - 30 (69 - 207)	14 - 30 (97 - 207)
		lbf (N)	lbf (N)	lbf (N)	lbf (N)	lbf (N)	lbf (N)
1069 and 2069	3/4 (19) to 1-1/2 (38)	207 (921)	414 (1842)	552 (2455)	414 (1842)	690 (3069)	966 (4297)
2105 and 3105	3/4 (19) to 2 (51)	315 (1401)	630 (2802)	966 (4297)	630 (2802)	1050 (4671)	1470 (6530)
2156 and 3156	3/4 (19) to 2 (51)	468 (2082)	936 (4164)	1248 (5551)	936 (4164)	1560 (6939)	2184 (9715)
3220	3/4 (19) to 2 (51)	660 (2936)	1320 (5872)	1760 (7829)	1320 (5872)	2200 (9786)	3080 (13700)

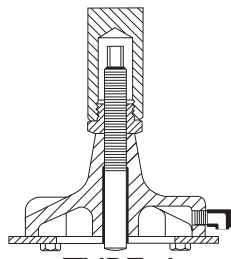

**TYPE 4
UP STOP DFC**

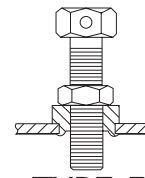

**TYPE 5
UP STOP DFC**

Figure 6 Optional Adjustable Travel Stops Continued

Our Commitment of Quality

Dyna-Flo is committed to continuous improvement. All efforts have been taken to maximize the accuracy of this information. Without notification, product specifications and designs may be modified at any time. The issue of this document is for information only, and does not imply suitability, a warranty, or guarantee for a specific service.



Model DFC AND DFO Valve Actuator

Dyna-Flo DFC / DFO Series Actuators | Model Numbering System

Ordering Guide

Sample Part Number

DFC - 2 069 - B H N - X

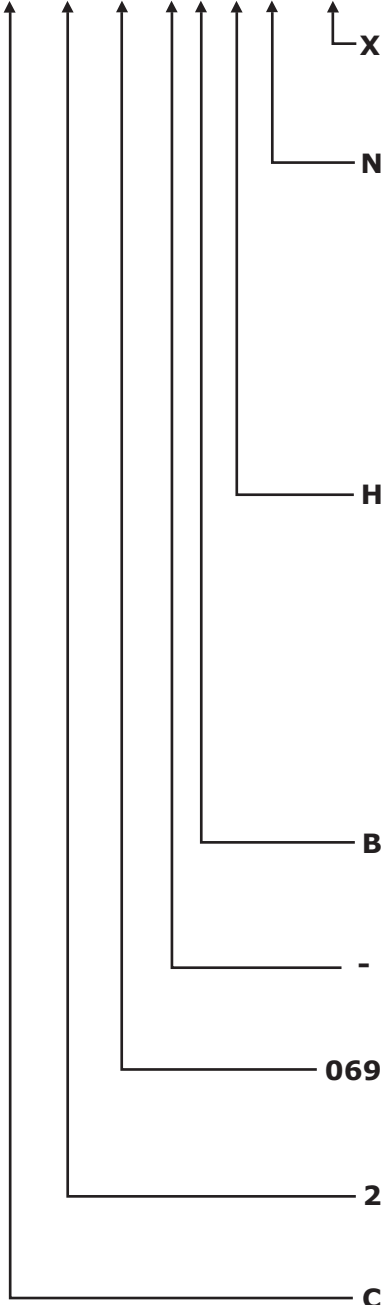

X	Denotes Special Construction	
X	Special (Consult Dyna-Flo Sales Office)	
Options		
N	None (Standard)	2 Type 2 Down Stop - DFO
S	Side Mounted Handwheel	3 Type 3 Down Stop - DFC
T	Top Mounted Handwheel	4 Type 4 Up Stop - DFC
1	Type 1 Up Stop - DFO	5 Type 5 Up Stop - DFC
Bench Range, psig		
FAIL CLOSED		FAIL OPEN
A	3 - 15	H 6 - 30
B	4 - 15	Y 8 - 30
C	5 - 15	I 9 - 30
D	6 - 15	J 10 - 30
E	7 - 15	K 12 - 30
F	8 - 15	L 14 - 30
U	9 - 15	M 15 - 30
G	10 - 15	N 16 - 30
V	11 - 15	O 17 - 30
X	Special	P 18 - 30
		Q 19 - 30
		R 20 - 30
		S 21 - 30
		T 22 - 30
		W 14 - 26
		A 3 - 15
		B 3 - 14
		C 3 - 13
		D 3 - 12
		E 3 - 11
		F 3 - 10
		G 3 - 8
		X Special
		H 6 - 30
		I 6 - 28
		J 6 - 27
		K 6 - 26
		L 6 - 24
		M 6 - 22
		N 6 - 21
		O 6 - 20
		P 6 - 19
		Q 6 - 18
		R 6 - 17
		S 6 - 16
		T 6 - 15
		U 6 - 23
Travel, Inch		
A	3/4	D 2
B	1-1/8	E 2-1/2
C	1-1/2	F 3
		G 3-1/2
		X Special Travel
Paint		
-	Standard Dyna-Flo Paint	
W	International Paint - Willow Grey Color No. 80898	
Actuator Size, in²		
069	69	156 156
105	105	220 220
Valve Yoke, Inch		
1	2-1/8	S Short 2-13/16
2	2-13/16	
3	3-9/16	
Action		
C	Fail Closed	O Fail Open