



## Model 390 Control Valve



**Figure 1** Model 390 Control Valve with DFC Actuator

The Model 390 control valve (Figure 1) is a heavy duty globe style control valve. This valve is used in all kinds of demanding applications, including oil and gas production and chemical process. Metal seats are used for increased seat life.

Model 390 valves are cage guided, single port valves that can be used in either snap on/off acting or throttling applications of either liquids or gases. A bolted bonnet is standard and a typical actuator is a Dyna-Flo DFC or DFO model linear actuator.

### Features

#### High Quality Construction

Dyna-Flo uses only materials that have been proven to provide superior, trouble free performance. All materials comply with ASME and ASTM specifications.

#### Versatility

A wide range of trim options including Low Noise and Anti-Cavitation make the 390 a highly versatile control valve.

#### Field Service Friendly

No special tools are required to change or inspect trim. Top access makes in-line service easy.

#### Industrial High Quality External Coatings

Our standard industrial high quality external coatings provide long lasting resistance to the harshest environments.

#### Pressure Drop Capabilities

The Model 390 can shut off against inlet pressure equal to ASME B16.34 rating.

#### Sour Gas Service Capability

The Model 390 can be constructed out of materials that comply with the recommendations of the National Association of Corrosion Engineers (NACE) MR-0175.

#### Shut Off Classification

Seat leakage options range from ASME/FCI class II to class V.

#### Plug Design

Standard balanced plug design allows the use of smaller actuators.

#### Environmentally Friendly

Available with low emission live loaded packing.



## Model 390 Control Valve

### Specifications

#### Configurations

See Table 1

Consult your Dyna-Flo sales office for other available configurations.

#### Sizes and Connection Styles

Models: 390  
Size: 2", 3", 4", 6"  
Rating: ASME 900 or 1500  
Connections: RF / RTJ

#### Maximum Inlet Temperatures and Pressures

Consistent with ASME class rating as per ASME B16.34, unless limited by either material, pressure or temperature limitations.

#### Maximum Pressure Drops

Same as maximum inlet pressure unless otherwise rated by specific trim construction. For Actuator and Valve assembly shut off pressure drops see Tables 8 and 9.

#### Standard Seat Leakage Classifications

See Table 1.

#### Dimensions

Valve and Actuator Assembly Dimensions  
See Table 3 & 4

Valve and Actuator Assembly Dimensions  
See Figure 2

#### Approximate Valve Body and Actuator Weights

See Table 2

#### Valve Body to Bonnet Bolting

Standard service body to bonnet:  
SA193-B7 Studs  
SA-194-2H Nuts

For NACE-2003  
SA-193-B7M Studs  
SA-194-2HM Nuts

#### Characteristics

- Equal Percentage (Standard)
- Modified Equal Percentage (Same cage as Equal Percentage, different travel)
- Linear
- Anti-Cavitation Stage 2
- Anti-Cavitation Stage 3

#### Packing Type

The standard packing is PTFE V-Ring. Live loaded low emission, graphite and other packing arrangements are also available.

#### Valve Sizing Coefficients

See Table 5

#### Valve Travel and Yoke Boss Sizes

See Table 10

#### Trim Materials

See Table 11

#### Valve Bolting Temperature Limitations

See Table 12

#### Valve Parts List, Material and Temperature Limitations

See Table 6, 7, 11 and 12

See Figure 4



Model  
**390** Control Valve

**Table 1**

**Valve Design Configurations**

Valve Model	Size (inch)	Shut Off Capability	Valve Plug	Seal Ring	Guide	Seat
390	2, 3, 4, 6	IV Standard	Balanced	Carbon PTFE with R30003 Spring	Cage	Metal
	2, 3, 4, 6	V Optional Standard For Anti-Cavitation Trim	Balanced	Carbon PTFE with R30003 Spring	Cage	Metal

**Table 2**

**Approximate Weights lb (kg)**

Valve Size (inch)	Class	Body Only	With Fail Open Actuator	Assembly Weight	With Fail Close Actuator	Assembly Weight
2	900 / 1500	160 (73)	DFO-2105	242 (110)	DFC-2105	250 (114)
3	900	275 (125)	DFO-2105	357 (162)	DFC-2105	365 (166)
3	1500	286 (130)	DFO-3156	402 (183)	DFC-3156	408 (185)
4	900	510 (231)	DFO-3156	626 (284)	DFC-3156	632 (286)
4	1500	552 (250)	DFO-3220	787 (357)	DFC-3156	806 (366)
6	900	1125 (510)	DFO-3220	1360 (617)	DFC-3220	1379 (626)



Model  
**390** Control Valve

**Table 3**

**Models 390 Standard Valve Dimensions** Inches (mm) (Refer to Figure 2)

Valve Size	ASME Class	Actuator Size	Dimension				
			A	B	D	D	E
					DFO	DFC	
2"	900 / 1500 <b>RF</b>	2105	14.75 (375)	3.06 (78)	25.90 (658)	30.30 (770)	16.00 (406)
	900 / 1500 <b>RTJ</b>	2105	14.88 (378)	3.06 (78)	25.90 (658)	30.30 (770)	16.00 (406)
3"	900 <b>RF</b>	2105	17.38 (441)	4.75 (121)	25.90 (658)	30.30 (770)	16.00 (406)
	900 <b>RTJ</b>	2105	17.50 (445)	4.75 (121)	25.90 (658)	30.30 (770)	16.00 (406)
	1500 <b>RF</b>	2156	18.13 (460)	4.75 (121)	25.80 (655)	29.40 (747)	18.62 (473)
	1500 <b>RTJ</b>	2156	18.25 (464)	4.75 (121)	25.80 (655)	29.40 (747)	18.62 (473)
3"	900 <b>RF</b>	3156	17.38 (441)	4.75 (121)	28.40 (721)	30.90 (785)	18.62 (473)
	900 <b>RTJ</b>	3156	17.50 (445)	4.75 (121)	28.40 (721)	30.90 (785)	18.62 (473)
	1500 <b>RF</b>	3156	18.13 (461)	4.75 (121)	28.40 (721)	30.90 (785)	18.62 (473)
	1500 <b>RTJ</b>	3156	18.25 (464)	4.75 (121)	28.40 (721)	30.90 (785)	18.62 (473)
4"	900 <b>RF</b>	3156	20.12 (511)	6.88 (175)	28.40 (721)	30.90 (785)	18.62 (473)
	900 <b>RTJ</b>	3156	20.25 (514)	6.88 (175)	28.40 (721)	30.90 (785)	18.62 (473)
	1500 <b>RF</b>	3220	20.88 (530)	6.88 (175)	33.10 (841)	36.80 (935)	21.12 (536)
	1500 <b>RTJ</b>	3220	21.00 (533)	6.88 (175)	33.10 (841)	36.80 (935)	21.12 (536)
6"	900 <b>RF</b>	3220	28.12 (714)	9.75 (248)	33.10 (841)	36.80 (935)	21.12 (536)
	900 <b>RTJ</b>	3220	28.25 (718)	9.75 (248)	33.10 (841)	36.80 (935)	21.12 (536)



Model  
**390** Control Valve

**Table 4**

**Model 390 Dimension C for Standard Bonnet Diameters**  
Inches (mm) (Refer to Figure 2)

Valve Size (Inch)	Dimension C		
	2-13/16 (71) Yoke Boss Diameter	3-9/16 (90) Yoke Boss Diameter	5 (127) Yoke Boss Diameter
2	10.31 (261)	10.56 (267)	—
3	12.69 (322)	12.25 (311)	—
4	—	11.81 (300)	—
6	—	14.38 (365)	15.81 (402)

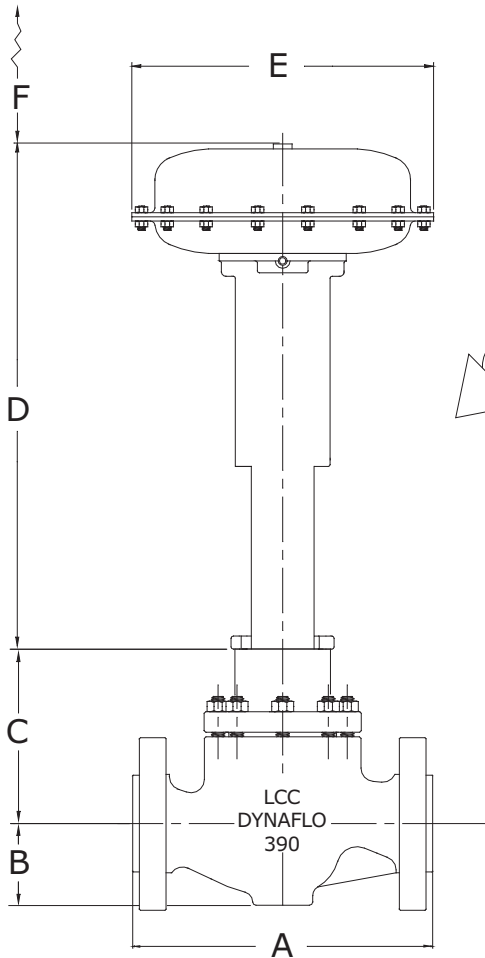

**Figure 2** Typical Valve Assembly with Type DFC or DFO

F Dimension:

2" Valve	6.88" (175 mm)
3" Valve	6.88" (175 mm)
3" Valve	9.12" (232 mm)
For DFC/DFO 3156	
4" Valve	9.12" (232 mm)
6" Valve	9.12" (232 mm)



Model  
**390** Control Valve

**Table 5**

**Models 390 Valve Sizing Coefficients**

**Linear**

Valve Size	Port Inches (mm)	Travel Inches (mm)	Coefficient	Percentage of Valve Travel									
				10%	20%	30%	40%	50%	60%	70%	80%	90%	100%
2"	1-7/8 (47.6)	1-1/2 (38.1)	C <sub>V</sub>	-	3.49	12.5	22.9	31.8	38.4	43.0	46.7	49.9	52.1
			X <sub>T</sub>	-	0.811	0.632	0.682	0.743	0.829	0.78	0.743	0.726	0.697
			F <sub>L</sub>	0.91	0.91	0.91	0.91	0.91	0.91	0.91	0.91	0.91	0.91
3"	2-7/8 (73)	2 (50.8)	C <sub>V</sub>	-	8.72	31.5	55.1	74.6	89.4	101	110	117	121
			X <sub>T</sub>	-	0.589	0.589	0.653	0.728	0.775	0.795	0.791	0.777	0.773
			F <sub>L</sub>	0.93	0.93	0.93	0.93	0.93	0.93	0.93	0.93	0.93	0.93
4"	3-5/8 (92.1)	2 (50.8)	C <sub>V</sub>	6.91	26.5	26.5	86.4	117	143	165	182	194	201
			X <sub>T</sub>	0.327	0.581	0.581	0.509	0.525	0.602	0.673	0.708	0.714	0.726
			F <sub>L</sub>	0.91	0.91	0.91	0.91	0.91	0.91	0.91	0.91	0.91	0.91
6"	5-3/8 (136.5)	3 (76.2)	C <sub>V</sub>	8.78	63.3	149	231	298	351	385	407	424	425
			X <sub>T</sub>	0.763	0.613	0.544	0.573	0.620	0.670	0.721	0.745	0.709	0.726
			F <sub>L</sub>	0.91	0.91	0.91	0.91	0.91	0.91	0.91	0.91	0.91	0.91

**Equal Percent**

Valve Size	Port Inches (mm)	Travel Inches (mm)	Coefficient	Percentage of Valve Travel									
				10%	20%	30%	40%	50%	60%	70%	80%	90%	100%
2"	1-7/8 (47.6)	1-1/8 (28.6)	C <sub>V</sub>	-	1.02	3.26	7.53	13.3	19.8	26.4	32.0	36.2	41.0
			X <sub>T</sub>	-	0.745	0.619	0.595	0.587	0.593	0.633	0.721	0.791	0.791
			F <sub>L</sub>	0.93	0.93	0.93	0.93	0.93	0.93	0.93	0.93	0.93	0.93
3"	2-7/8 (73)	1-1/2 (38.1)	C <sub>V</sub>	-	1.21	4.21	11.3	23.0	37.6	53.2	69.5	85.3	92.5
			X <sub>T</sub>	-	0.954	0.761	0.600	0.558	0.592	0.661	0.705	0.706	0.762
			F <sub>L</sub>	0.92	0.92	0.92	0.92	0.92	0.92	0.92	0.92	0.92	0.92
4"	3-5/8 (92.1)	1-1/2 (38.1)	C <sub>V</sub>	3.12	7.35	13.9	23.4	37.9	60.1	90.6	123	147	164
			X <sub>T</sub>	0.676	0.551	0.524	0.488	0.449	0.443	0.463	0.509	0.569	0.674
			F <sub>L</sub>	0.85	0.85	0.85	0.85	0.85	0.85	0.85	0.85	0.85	0.85
6"	5-3/8 (136.5)	2-1/2 (63.5)	C <sub>V</sub>	3.9	13.3	23.1	36.2	63.0	105	156	217	280	319
			X <sub>T</sub>	0.961	0.686	0.615	0.584	0.540	0.513	0.496	0.480	0.513	0.586
			F <sub>L</sub>	0.82	0.82	0.82	0.82	0.82	0.82	0.82	0.82	0.82	0.82



Model  
**390** Control Valve

**Table 5 Continued**

**Modified Equal Percent**

Valve Size	Port Inches (mm)	Travel Inches (mm)	Coefficient	Percentage of Valve Travel									
				10%	20%	30%	40%	50%	60%	70%	80%	90%	100%
2"	1-7/8 (47.6)	1-1/2 (38.1)	C <sub>V</sub>	-	2.28	7.52	15.7	24.1	31.6	38.2	43.5	46.7	48.7
			X <sub>T</sub>	-	0.641	0.571	0.584	0.634	0.698	0.778	0.803	0.771	0.760
			F <sub>L</sub>	0.93	0.93	0.93	0.93	0.93	0.93	0.93	0.93	0.93	0.93
3"	2-7/8 (73)	2 (50.8)	C <sub>V</sub>	0.475	3.07	11.8	26.8	46.6	69.3	89.5	100	103	114
			X <sub>T</sub>	0.949	0.712	0.55	0.604	0.682	0.697	0.706	0.762	0.856	0.771
			F <sub>L</sub>	0.95	0.95	0.95	0.95	0.95	0.95	0.95	0.95	0.95	0.95
4"	3-5/8 (92.1)	2 (50.8)	C <sub>V</sub>	4.33	11.3	23.3	45.0	79.6	121	155	176	192	202
			X <sub>T</sub>	0.624	0.523	0.482	0.45	0.453	0.502	0.599	0.696	0.723	0.735
			F <sub>L</sub>	0.89	0.89	0.89	0.89	0.89	0.89	0.89	0.89	0.89	0.89
6"	5-3/8 (136.5)	3 (76.2)	C <sub>V</sub>	5.22	16.6	30.8	55.0	100	168	241	299	351	378
			X <sub>T</sub>	0.883	0.725	0.571	0.597	0.592	0.514	0.526	0.623	0.667	0.717
			F <sub>L</sub>	0.89	0.89	0.89	0.89	0.89	0.89	0.89	0.89	0.89	0.89

For linear and quick opening valve characteristics please contact Dyna-Flo

**Relationships of Note:**

$$C_1 = 39.76 \sqrt{X_T}$$

$$C_G = C_V C_1$$

$$K_M = F_L^2$$

**! NOTE !** - Modified Equal Percent is a factor of travel and requires no special trim options above Equal Percent.



## Model 390 Control Valve

Table 5 Continued

### Models 390 Valve Sizing Coefficients Two Stage Anti-Cavitation

Valve Size	Port Inches (mm)	Travel Inches (mm)	Coefficient	Percentage of Valve Travel									
				10%	20%	30%	40%	50%	60%	70%	80%	90%	100%
2"	1-3/4 (44.5)	2 (50.8)	$C_v$	1.07	1.97	3.29	4.86	6.58	8.36	10.1	11.7	13.0	14.0
			$F_L$	0.98	0.98	0.98	0.98	0.98	0.98	0.98	0.98	0.98	0.98
3"	2-1/2 (63.5)	2-1/2 (63.5)	$C_v$	1.46	4.98	9.24	13.2	17.0	20.7	24.7	28.5	31.9	34.4
			$F_L$	0.98	0.98	0.98	0.98	0.98	0.98	0.98	0.98	0.98	0.98
4"	3-7/16 (87.3)	3 (76.2)	$C_v$	2.61	9.01	15.6	21.8	28.3	34.8	40.4	46.4	52.2	58.0
			$F_L$	0.98	0.98	0.98	0.98	0.98	0.98	0.98	0.98	0.98	0.98
6"	5-1/4 (133.4)	4 (101.6)	$C_v$	7.50	20.7	33.8	47.0	60.1	73.3	87.0	100	112	123
			$F_L$	0.98	0.98	0.98	0.98	0.98	0.98	0.98	0.98	0.98	0.98

Minimum Throttling $C_v^2$	Valve Size			
	2 inch	3 inch	4 inch	6 inch
	0.580	0.720	0.900	1.72

- The 2 inch three stage anti-cavitation valves have unbalanced plugs, these valves are of a Model 392 valve design.
- Valves should not be throttled at a Cv less than the specified minimum throttling Cv for extended periods of time, erosion damage to valve trim may occur.

NOTE: All  $F_L$  values are at 100% travel.

### Models 390 Valve Sizing Coefficients Three Stage Anti-Cavitation

Valve Size	Port Inches (mm)	Travel Inches (mm)	Coefficient	Percentage of Valve Travel									
				10%	20%	30%	40%	50%	60%	70%	80%	90%	100%
2" <sup>1</sup>	1 (25.4) <sup>1</sup>	2 (50.8)	$C_v$	0.272	1.10	1.98	2.80	3.63	4.46	5.30	6.07	6.61	6.73
			$F_L$	0.99	0.99	0.99	0.99	0.99	0.99	0.99	0.99	0.99	0.99
3"	1-7/8 (47.6)	2-1/2 (63.5)	$C_v$	0.747	20.0	3.92	6.15	8.00	9.50	11.0	12.8	14.9	16.5
			$F_L$	0.99	0.99	0.99	0.99	0.99	0.99	0.99	0.99	0.99	0.99
4"	2-7/8 (73)	3 (76.2)	$C_v$	2.80	5.50	8.30	11.0	13.9	16.7	19.4	22.2	25.0	27.8
			$F_L$	0.99	0.99	0.99	0.99	0.99	0.99	0.99	0.99	0.99	0.99
6"	4-9/16 (115.9)	4 (101.6)	$C_v$	6.10	13.2	19.8	26.1	34.1	41.5	48.2	54.5	60.9	65.0
			$F_L$	0.99	0.99	0.99	0.99	0.99	0.99	0.99	0.99	0.99	0.99

Minimum Throttling $C_v^2$	Valve Size			
	2 inch	3 inch	4 inch	6 inch
	0.590	1.20	1.70	3.10

- The 2 inch three stage anti-cavitation valves have unbalanced plugs, these valves are of a Model 392 valve design.
- Valves should not be throttled at a Cv less than the specified minimum throttling Cv for extended periods of time, erosion damage to valve trim may occur.

NOTE: All  $F_L$  values are at 100% travel.



Model  
**390** Control Valve

**Table 6**

**Typical Construction Materials**

Key	Part Description	Standard Construction	NACE Construction
1	BODY	SA352 Gr LCC	SA352 Gr LCC
2	BONNET	SA352 Gr LCC	SA352 Gr LCC
3	PACKING BOX RING	S31600	S31600
4	PACKING SPRING	S30400	-
5	LANTERN RING	-	S31600
6	RETAINING RING	S30200	S30200
7	SPECIAL WASHER	S30400	-
8	V-RING PACKING SET	PTFE	PTFE (Double)
9	PACKING FOLLOWER	S31600	S31600
10	STEM WIPER	FELT	FELT
11	CAGE	S17400	S17400 DH1150
12	VALVE PLUG / STEM ASS'Y	S41600 PLUG/ S20910 STEM	S31600 with CoCr-A SEAT & GUIDE S20910 Stem
13	SEAT RING	S41600	S31600-CoCr-A
14	SEAL RING	CARBON / PTFE / R30003	CARBON / PTFE / R30003
15	BACKUP RING	S31600	S31600
16	PACKING FLANGE	CARBON STEEL-PLATED	CARBON STEEL-PLATED
17	PACKING NUT	SA-194 2H	SA-194 2H
18	PACKING STUD	SA-193 B7	SA-193 B7
19	BONNET STUD	SA-193 B7	SA-193 B7M
20	BONNET NUT	SA-194 2H	SA-194 2HM
21	SEAT RING GASKET	N06600 / GRAPHITE	N06600 / GRAPHITE
22	BONNET GASKET	N06600 / GRAPHITE	N06600 / GRAPHITE



Model  
**390** Control Valve

**Table 7**

**Typical Construction Materials Cont'd**

Key	Part Description	Standard CF8M Construction
1	BODY	SA351 Gr CF8M
2	BONNET	SA351 Gr CF8M
3	PACKING BOX RING	S31600
4	PACKING SPRING	-
5	LANTERN RING	S31600
6	RETAINING RING	S30200
7	SPECIAL WASHER	-
8	PACKING SET	PTFE (Double)
9	PACKING FOLLOWER	S31600
10	UPPER WIPER	FELT
11	CAGE	S31600 / ENC
12	VALVE PLUG / STEM ASS'Y	S31600 with CoCr-A SEAT & GUIDE S20910 Stem
13	SEAT RING	S31600-CoCr-A
14	SEAL RING / PISTON RING	CARBON / PTFE / R30003
15	BACKUP RING	S31600
16	PACKING FLANGE	CARBON STEEL-PLATED
17	PACKING NUT	8M
18	PACKING STUD	SA-194 B8M
19	BONNET STUD	SA-194 B8M
20	BONNET NUT	8M
21	SEAT RING GASKET	N06600 / GRAPHITE
22	BONNET GASKET	N06600 / GRAPHITE



Model  
**390** Control Valve

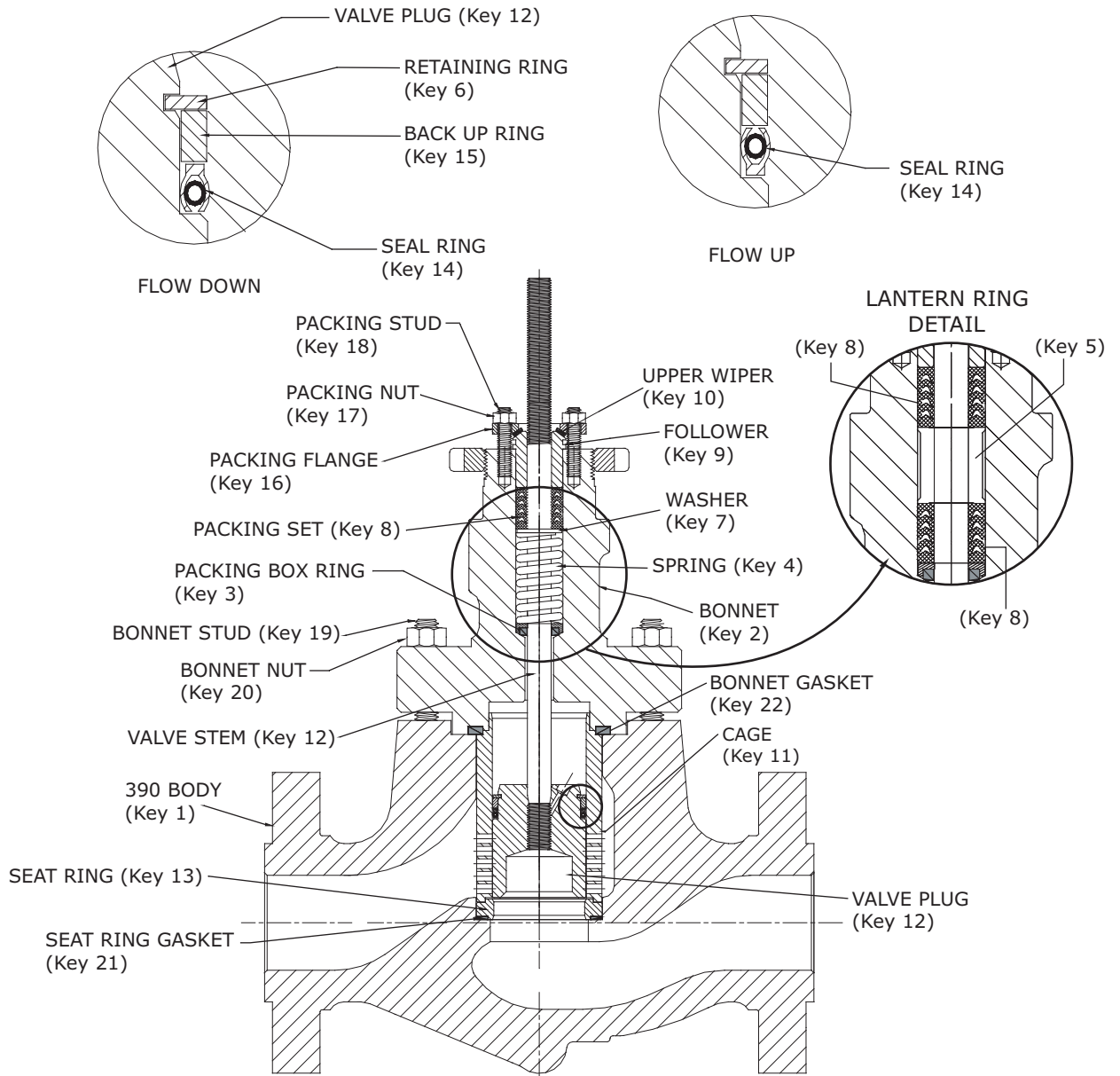

**Figure 3** Cross-section of 390 Series Control Valve



Model  
**390** Control Valve

**Table 8**

**Fail Open Actuator**  
Shut Off Capabilities for Model 390  
Metal Seat, Class IV Control Valve  
35 psig supply pressure

Valve Size (inch)	Actuator Size Pressure Drop Psig (kPag)				
	DFO - 2105	DFO - 2156	DFO - 3105	DFO - 3156	DFO - 3220
2"	3750 (25,855) <sup>1</sup>	3750 (25,855) <sup>1</sup>	—	—	—
3"	3750 (25,855) <sup>2</sup>	3750 (25,855) <sup>1</sup>	3750 (25,855) <sup>2</sup>	3750 (25,855) <sup>1</sup>	—
4"	—	—	—	3750 (25,855) <sup>3</sup>	3750 (25,855) <sup>1</sup>
6"	—	—	—	—	2280 (15,720) <sup>4</sup>

**Note**

- 1 - 6 to 26 Psig bench range
- 2 - 6 to 24 Psig bench range
- 3 - 6 to 22 Psig bench range
- 4 - 6 to 17 Psig bench range

**Table 9**

**Fail Closed Actuator**  
Shut Off Capabilities for Model 390  
Metal Seat, Class IV Control Valve  
35 psig supply pressure

Valve Size (inch)	Actuator Size Pressure Drop Psig (kPag)				
	DFC - 2105	DFC - 2156	DFC - 3105	DFC - 3156	DFC - 3220
2"	3750 (25,855) <sup>1</sup>	3750 (25,855) <sup>1</sup>	—	—	—
3"	3750 (25,855) <sup>2</sup>	3750 (25,855) <sup>1</sup>	3750 (25,855) <sup>2</sup>	3750 (25,855) <sup>1</sup>	—
4"	—	—	—	2280 (15,720) <sup>2</sup>	3750 (25,855) <sup>3</sup>
6"	—	—	—	—	2280 (15,720) <sup>4</sup>

**Note**

- 1 - 6 to 30 psig Bench Range
- 2 - 9 to 30 psig Bench Range
- 3 - 7 to 30 psig Bench Range
- 4 - 18 to 30 Psig Bench Range with a DFC4-3220 Actuator



Model  
**390** Control Valve

**Table 10**

**Port Diameters, Valve Plug Travel and Yoke Boss Diameter**

Valve Size Inch	Port Diameter Inch (mm)	Max Valve Travel Inch (mm)	Yoke Boss Diameter Inch (mm)	
			Stem	Valve
2" Linear & Mod. Equal Percent	1 7/8 (47.6)	1-1/2 (38.1)	1/2 (12.7)	2-13/16 (71.4)
			3/4 (19.1)	3-9/16 (90.5)
2" Equal Percent	1-7/8 (47.6)	1-1/8 (28.6)	1/2 (12.7)	2-13/16 (71.4)
			3/4 (19.1)	3-9/16 (90.5)
2" Anti-Cavitation Stage 2	1-3/4 (44.5)	2 (50.8)	1/2 (12.7)	2-13/16 (71.4)
			3/4 (19.1)	3-9/16 (90.5)
2" Anti-Cavitation Stage 3	1 (25.4)	2 (50.8)	3/4 (19.1)	3-9/16 (90.5)
3" Linear & Mod. Equal Percent	2-7/8 (73)	2 (50.8)	1/2 (12.7)	2-13/16 (71.4)
			3/4 (19.1)	3-9/16 (90.5)
			1 (25.4)	5 (127)
3" Equal Percent	2-7/8 (73)	1-1/2 (38.1)	1/2 (12.7)	2-13/16 (71.4)
			3/4 (19.1)	3-9/16 (90.5)
			1 (25.4)	5 (127)
3" Anti-Cavitation Stage 2	2-1/2 (63.5)	2-1/2 (63.5)	1/2 (12.7)	2-13/16 (71.4)
			3/4 (19.1)	3-9/16 (90.5)
			1 (25.4)	5 (127)
3" Anti-Cavitation Stage 3	1-7/8 (47.6)	2-1/2 (63.5)	1/2 (12.7)	2-13/16 (71.4)
			3/4 (19.1)	3-9/16 (90.5)
			1 (25.4)	5 (127)
4" Linear & Mod. Equal Percent	3-5/8 (98)	2 (50.8)	3/4 (19.1)	3-9/16 (90.5)
			1 (25.4)	5 (127)
			3/4 (19.1)	3-9/16 (90.5)
4" Equal Percent	3-5/8 (92.1)	1-1/2 (38.1)	1 (25.4)	5 (127)
			3/4 (19.1)	3-9/16 (90.5)
			1 (25.4)	5 (127)
4" Anti-Cavitation Stage 2	3-7/16 (87.3)	3 (76.2)	3/4 (19.1)	3-9/16 (90.5)
			1 (25.4)	5 (127)
4" Anti-Cavitation Stage 3	2-7/8 (73)	3 (76.2)	3/4 (19.1)	3-9/16 (90.5)
			1 (25.4)	5 (127)
6" Linear & Mod. Equal Percent	5-3/8 (136.5)	3 (76.2)	3/4 (19.1)	3-9/16 (90.5)
			1 (25.4)	5 (127)
			1-1/4 (31.8)	5 (127)
6" Equal Percent	5-3/8 (136.5)	2-1/2 (63.5)	3/4 (19.1)	3-9/16 (90.5)
			1 (25.4)	5 (127)
			1-1/4 (31.8)	5 (127)
6" Anti-Cavitation Stage 2	5-1/4 (133.4)	4 (101.6)	3/4 (19.1)	3-9/16 (90.5)
			1 (25.4)	5 (127)
			1-1/4 (31.8)	5 (127)
6" Anti-Cavitation Stage 3	4-9/16 (115.9)	4 (101.6)	3/4 (19.1)	3-9/16 (90.5)
			1 (25.4)	5 (127)
			1-1/4 (31.8)	5 (127)



Model  
**390** Control Valve

**Table 11**

**Common Trim Options and Temperature Ratings**

Trim <sup>4</sup> Spec	Valve Plug	Stem	Cage	Seat Ring	Minimum <sup>3</sup> Temperature	Maximum Temperature
					°F (°C)	°F (°C)
S	S41600	S20910	S17400 PH	S41600	-20 (-29)	650 (343) <sup>1</sup>
N	S31600 / CoCr-A Seat and Guide	S20910	S17400 PH DHT	S31600 / CoCr-A	-50 (-46)	650 (343)
C	S31600 / CoCr-A Seat and Guide	S20910	S31600 ENC	S31600 / CoCr-A	-20 (-29)	750 (399) <sup>2</sup>

- 1 Maximum temperature limited by LCC body material
- 2 When used with CF8M or WCC body material
- 3 Temperatures need to be considered when specifying trim materials for elevated temperatures in corrosive environments, consult factory for further information
- 4 Trim Spec relates to Model Numbering System on Page 12

NOTE: Bonnet Bolting refer to Table 12

**Table 12**

**Valve Bolting Temperature Limitations**

Stud Material	Temperature Limitation
B7	-50°F to 900°F (-46°C TO 482°C)
B7M	-50°F TO 900°F (-46°C TO 482°C)
B8M	-325°F TO 1500°F (-198°C TO 816°C)
S17400 DH 1150	-50°F TO 650°F (-46°C TO 343°C)
Nut Material	Temperature Limitation
2H, 2HM & 8M	Not Limiting Factors



# Model 390 Control Valve

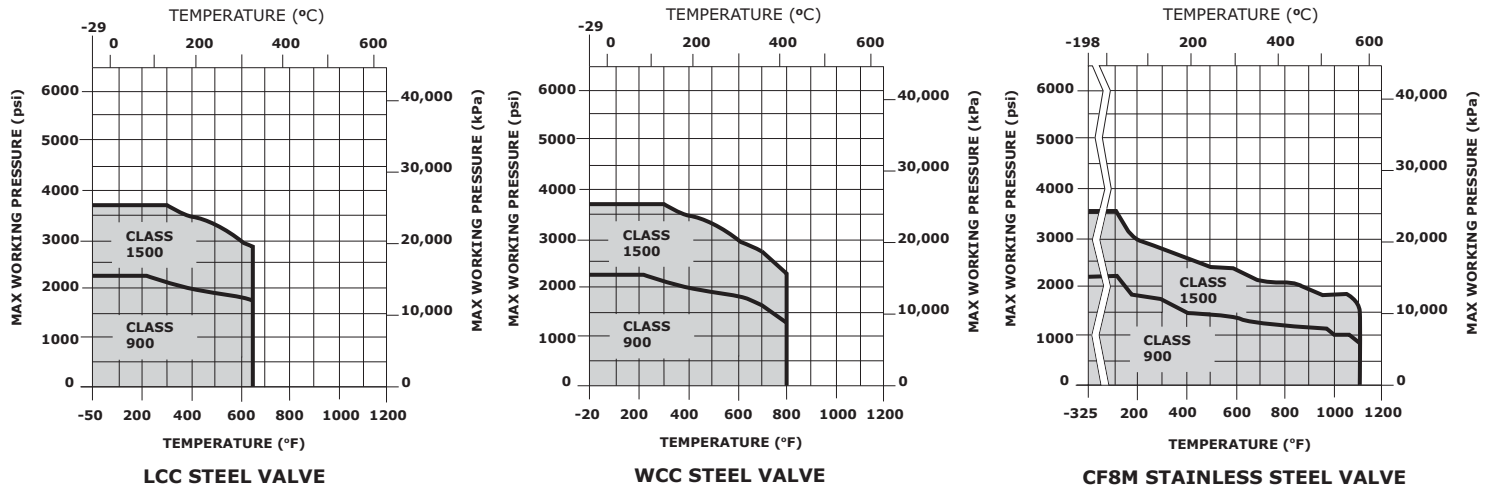

**Figure 4** Pressure / Temperature Charts as per ASME B16.34

**Table 13**

**Materials and Temperature Limits  
Parts other than Valve Body and Trim**

Part	Material	Minimum Temperature	Maximum Temperature
Backup Ring	S31600	-325°F (198°C)	1100°F (593°C)
Retaining Ring	S30200	-425°F (-254°C)	1100°F (593°C)
Seal Ring	PTFE with R30003 Spring	-100°F (-73°C)	450°F (232°C)
Bonnet / Cage Gasket	N06600 / Graphite	-400°F (-240°C)	800°F (427°C)
Seat Ring Gasket	N06600 / Graphite	-400°F (-240°C)	800°F (427°C)
Packing	PTFE V-Ring	-40°F (-40°C)	450°F (232°C)
	Graphite Ribbon / Filament	-425°F (-254°C)	1000°F (537°C)
Body to Bonnet Studs (NACE-2002)	B7M (LCC Body)	-50°F (-46°C)	700°F (371°C)
Body to Bonnet Nuts (NACE-2002)	2HM (LCC Body)	-50°F (-46°C)	700°F (371°C)

For NACE 2003 body to bonnet studs and nuts please contact Dyna-Flo



Model  
**390** Control Valve

Ordering Guide

**Dyna-Flo Model 390 Control Valve | Model Numbering System**

Sample Part Number

**390-3AJ-L2S-EP**

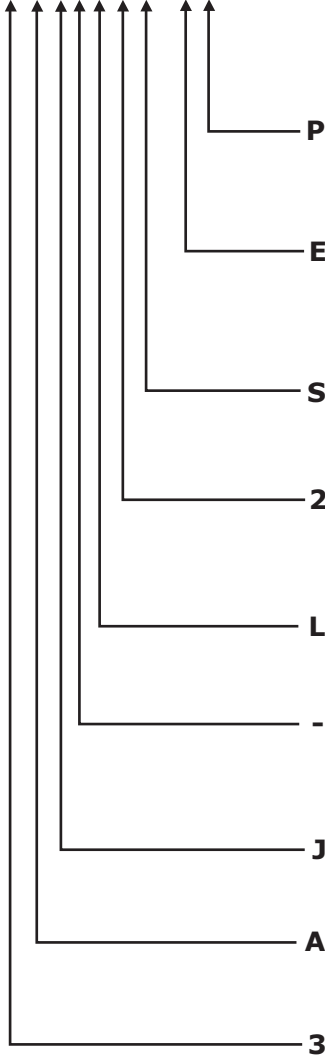

Code	Description
<b>Packing Style</b>	
<b>P</b>	Spring Loaded PTFE V-Ring
<b>D</b>	Double PTFE V-Ring
<b>G</b>	Graphite High Temp
<b>T</b>	Live Loaded (PTFE)
<b>Characteristic</b>	
<b>L</b>	Linear
<b>E</b>	Equal Percent
<b>3</b>	Anti-Cavitation 3 Stage
<b>2</b>	Anti-Cavitation 2 Stage
<b>M</b>	Modified Equal Percent
<b>Trim</b>	
<b>S</b>	Standard
<b>N</b>	NACE / Low Temp
<b>C</b>	CF8M Construction
<b>Bonnet</b>	
<b>2</b>	2-13/16" (71.4 mm)
<b>5</b>	5" (127 mm)
<b>3</b>	3-9/16" (90.5 mm)
<b>Body Material</b>	
<b>L</b>	LCC
<b>W</b>	WCC
<b>M</b>	CF8M
<b>Bolting</b>	
<b>-</b>	B7 / 2H (Standard)
<b>B</b>	B8M / 8M
<b>A</b>	B7M / 2HM
<b>C</b>	S17400 DH 1150 / 2HM
<b>Connection Style</b>	
<b>F</b>	RF
<b>J</b>	RTJ
<b>ASME Rating</b>	
<b>A</b>	900
<b>B</b>	1500
<b>C</b>	900/1500
<b>Valve Size</b>	
<b>2</b>	2 inch
<b>3</b>	3 inch
<b>4</b>	4 inch
<b>6</b>	6 inch

**! NOTE !** - Modified Equal Percent is a factor of travel and requires no special parts or trim options that differ from Equal Percent.

***Our Commitment of Quality***

Dyna-Flo is committed to continuous improvement. All efforts have been taken to maximize the accuracy of this information. Without notification, product specifications and designs may be modified at any time. The issue of this document is for information only, and does not imply suitability, a warranty, or guarantee for a specific service.